



# The *FlakSheet*

September 2014  
*All the News We Make Up to Fit*







*Robert Fair winning USS Pittsburgh CA-72 at the 2005 NCT Christmas Party*

## The Prez Sez! Elections!

Summer is almost over, the kids (and grandkids) are back in school, fall is almost upon us, the Cowboys are off to another losing season, and it's time for another meeting! We have a lot on the agenda this month, so be prepared for a longer-than-usual session.

Our esteemed and talented newsletter editor Frank Landrus will be presenting the program this month, namely, slides from this year's national convention in Hampton, Virginia. Frank will be making use of our new Epson VS330 digital projector, recently purchased using club funds.

Anyone with a laptop who wishes to present a program at future meetings is eligible to use it. It is compatible with both PC and Mac, and can be connected by means of S-Video, HDMI, USB, or VGA, RCA video, or component video to VGA cable, but you'll need to visit the Epson web site ([www.epson.com/cgi-bin/Store/support/SupportIndex.jsp](http://www.epson.com/cgi-bin/Store/support/SupportIndex.jsp)) and download the software and install it. Member Stuart Boyle graciously donated a backpack to hold the projector and accessories, and also donated a set of stereo speakers to use with the projector. Thanks, Stuart! The projector is a great asset that we have needed and should enhance future presentations.

Our new club shirts arrived in time for members attending the national convention to wear them and

show our colors, and they looked spiffy! Some of you who ordered have not yet paid for and picked up your shirt, so I encourage you to do so ASAP in order that our treasurer can close out this item before he has a nervous breakdown.

Speaking of the convention, I'm sure most of you know by now that IPMS-NCT member Robert Fair tragically and suddenly passed away while attending the convention. Randy Spurr and I were honored to serve as pallbearers at his funeral, and I delivered some brief remarks on behalf of the Chapter. An edited version has been submitted to the *IPMS Journal* for publication, and is included here for those who do not receive the *Journal*. We will have more to say about this at the meeting.

Randy and I will also have some news about ScaleFest 2015 to report. In case you haven't heard, next year's ScaleFest has been approved as the IPMS Region VI convention, so we have a lot of planning ahead. Finally, although it's hard to believe, it's time once again for election of officers! As you probably recall, Randy Spurr and I were elected last year about this time to serve out the terms of Vice-President John Walen and President Don Capone respectively, both of whom had to step down for various reasons. According to our Constitution and By-Laws, officers serve two-year terms, or so I've been told; I've never seen a copy of either! So think about whom you want to serve as President, Vice-President, Secretary, and Treasurer for the next two years and be prepared to vote for the candidates of your choice.

That's all, folks! See ya at the meeting.

(I'm not really a pompous ass ... I just play one on Hyperscale!)

*Michael*

*Michael McMurtrey, IPMS-USA 1746  
IPMS-Canada 1426  
President, IPMS-North Central Texas  
Proud IPMS NCT member since 2013*



*Robert Fair winning U-47 at the 2006 NCT Christmas Party*



Services for Robert Milton Fair, 59, of Tyler, were held on Friday, Aug. 15, 2014, at 11 a.m. at Marvin United Methodist Church Chapel with the Rev. Matthew Boulter and the Rev. Gerry Giles officiating.

Burial will follow in Rose Hill Cemetery in Tyler under direction of Stewart Family Funeral Home.

Mr. Fair was born March 19, 1955, in Tyler and died on Aug. 9, 2014, in Hampton, Va.

He was proud to be the grandson of the late R.W. Fair, and was happy to see the dedication of the Fair Family parking garage. Mr. Fair was a proud associate of Fair Oil Co. and the late R.W. Fair Family Foundation, which had made countless contributions to the city of Tyler and provided numerous scholarships to students in need.

Mr. Fair was a historian and enjoyed spending time with his grandchildren at many of the area attractions. Mr. Fair's precious granddaughters, Mia, Harper and Blayke, and daughter, Ashley, truly were his whole life.

Mr. Fair had a real passion as an avid modeler of all subjects, including military aircraft. He was a member of the I.P.M.S., president of the East Texas Modelers, and a member of I.P.M.S.-M.C.T.Mr.

Fair was preceded in death by parents, Wilton Harold Fair Sr., and wife Martha Imogene Fair; brothers, Wilton Harold Fair Jr. and Barton Walker Fair; and sister, Kay Elizabeth Fair.Mr.

Fair is survived by his beloved daughter, Ashley Harrison and husband Matt, of Tyler; his three beautiful grandchildren, Mia, Harper and Blayke; brother, David Fair and wife Carolyn, of Tyler; nephew, Walker Fair, of Houston; nieces, Laura Fair, of Greenville, and Genie Sullivan and husband David, of Dallas.

Pallbearers were Gus Ramirez, Gilbert Ramirez, Matt Harrison, Paul Clarkston, Randy Spurr, Ty Beard, Mike McMurtry and Rick Chandler. Honorary pallbearers were Paul Mitchell, Mike Tobin, Bobby Gorman, Gerald Saleh and Danny Saleh.

Visitation was from 6 to 8 p.m. Thursday, Aug. 14, 2014, at Stewart Family Funeral Home, 7525 Old Jacksonville Highway in Tyler.

In lieu of flowers, memorials may be made to One Love Network, in care of Hunger For Love, P.O. Box 7335, Tyler, 75711.







Since the end of this year's IPMS National convention in Hampton Virginia, things have been rather hectic. I am sure that most of you know of the passing of our friend and member Robert Fair of the East Texas Modelers in Tyler, Texas. Mike McMurtry and I were asked by the family to be pall bearers at the funeral which we were more than happy to do. Robert was taken ill during the banquet and passed away at the nearby hospital. Robert was laid to rest in the family plot at the Rose Hill Cemetery in Tyler, Texas on August 15, 2014.

I feel that it is fitting that we as then members of NCT do something to honor Robert's memory. I have been discussing this with the members of the E- Board on ways to do this. This will be part of our discussion at the meeting. I have since been in contact with the East Texas Modelers and asked them if they would be willing to co-sponsor s with what we do. They are willing to do so and plan on sponsoring the two of the Best of Trophies at the next year's Scale Fest in honor of two of their members who have passed this year.

Now on to a lighter note a time honored tradition will be reinstated this month. This is the awarding of the coveted PIG HAT. For those of you who do not know the meaning of the PIG HAT, it is awarded to those members who did not complete their participation in the clubs group build. The recipient(s) will be named at the meeting where all may see the awarding of the PIG HAT. So be there or be square to watch the frivolities. Frank; bring your camera!

Now for Scale Fest 2015, as promised, Mike and I will have a date set for the 2015 edition of Scale Fest. Once this is announced I would like to have our Facebook page and Website updated with the date. Now I hope you have been thinking of a theme for next year's Scale Fest so this may also be posted. The vendors should be sent a notification e-mail of the date so they can begin planning their next year's show schedule.

Next up is elections, as you may remember Mike and I were elected to fill out the terms of Don Capone and John Whalen who has to step down for personal reasons. The office of Secretary is also up for election as well as Treasurer. In order to be a member of the E-Board you must be a valid IPMS/USA member with a paid up membership to be elected. Please be thinking of what you would like to do and you will have my full and total support.

Now for the entertainment portion of the meeting I have asked Frank to put together a 35 to 45 minute slide show form the Nationals . Now we can see how the new projector works.

If you plan on bringing items to show off please limit them to one or two as we have a lot of things to cover this month. Next month will be the semi- annual fund raiser. So buy high and sell low. I have forgotten to tell you where the meeting will be held. We will be at the Garden and Arts Center for the rest of the year. The facility is located on Senter Street in Irving, Texas.

So until the meeting Happy Modeling and a big thank you to those who helped me get home from Virginia.

**Randy Spurr**

Vice President I.P.M.S/NCT IPMS # 7854



*Randy Spurr and Robert Fair at the Wounded Warriors Banquet held at the Virginia Air and Space Museum*



## The VP's Notes!

**September 14, 2014 1:00 pm**

**Elections!**

**IPMS Nationals Recap in Pictures!**

**2016 Club Build Selection!**

**Irving Garden & Arts Building**

Be sure to bring your 2015 Club build kits!

**October 12, 2014 1:00 pm**

**NCT Fundraiser**

**TBD**

**Irving Garden & Arts Building**

Be sure to bring your 2015 Club build kits!

**November 9, 2014 1:00 pm**

**Modeling Skills Workshop**

**TBD**

**Irving Garden & Arts Building**



## Fire Diver The First U-Boat

*Brandtaucher* (German for *Fire-diver*) was a submersible designed by the Bavarian inventor and engineer Wilhelm Bauer and built by Schweffel & Howaldt in Kiel for Schleswig-Holstein's Flotilla (part of the *Reichsflotte*) in 1850.

In January 1850 Bauer, a cavalryman during the German-Danish War, designed *Brandtaucher* as a way to end the Danish naval blockade of Germany. Bauer's early sketch attracted the attention of the Minister of Marine, who allowed him to construct a 70 × 18 × 29 cm (27.6 × 7.1 × 11.4 in) model.

The model was demonstrated in Kiel harbour in front of naval dignitaries. Its satisfactory performance led to the construction of a full-scale model, which was funded by contributions from army personnel and local civilians.



*Brandtaucher on display at the Bundeswehr Military History Museum, Dresden*

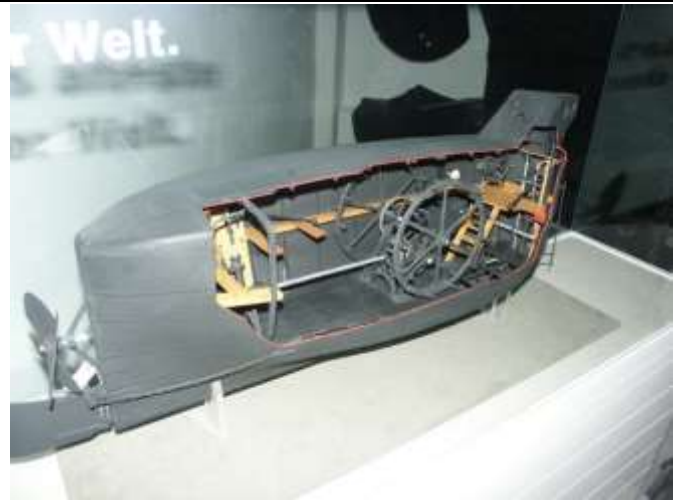

*The Brandtaucher submarine cutaway model in Dresden, Germany*

Due to the inadequate funding, the scale of the boat had to be downgraded and the design altered and simplified; resulting in a reduced diving depth from 30 m to 9.5 m. This redesign included eliminating the use of enclosed ballast tanks to contain the water being taken into and expelled from the submarine.

Instead, the water was allowed to pool inside the bottom of the hull, below the main floor, and was able to move relatively unobstructed within this area when the ship changed orientation. The resulting instability was probably a significant contributing factor to the loss of the vessel.

As built, *Brandtaucher* was 8.07 m long and 2.02 m at maximum beam, with a draught of 2.63 m. It was propelled by a crew of three turning large tread wheels connected to a propeller. The boat could reach a speed of three knots, but this could not be maintained for long periods of time.

On 1 February 1851, *Brandtaucher* sank after a diving accident during acceptance trials in Kiel Harbour. The submarine experienced equipment failure, and sank to the bottom of a 60-foot hole at the bottom of Kiel Harbour.



*Brandtaucher on display at the Bundeswehr Military History Museum, Dresden*



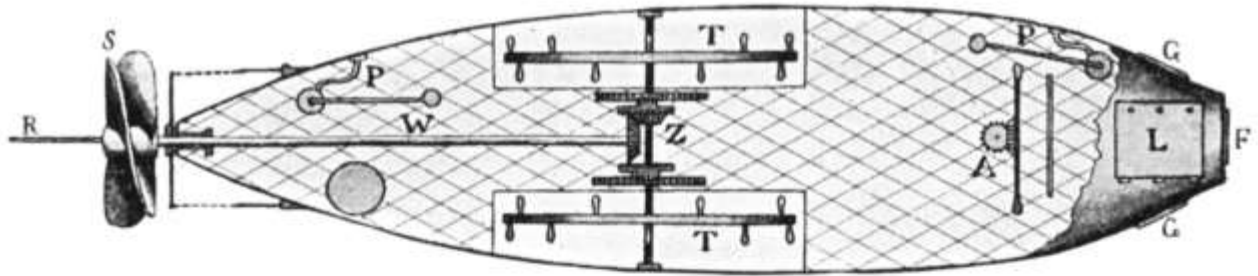

Das Innere, von oben gesehen.

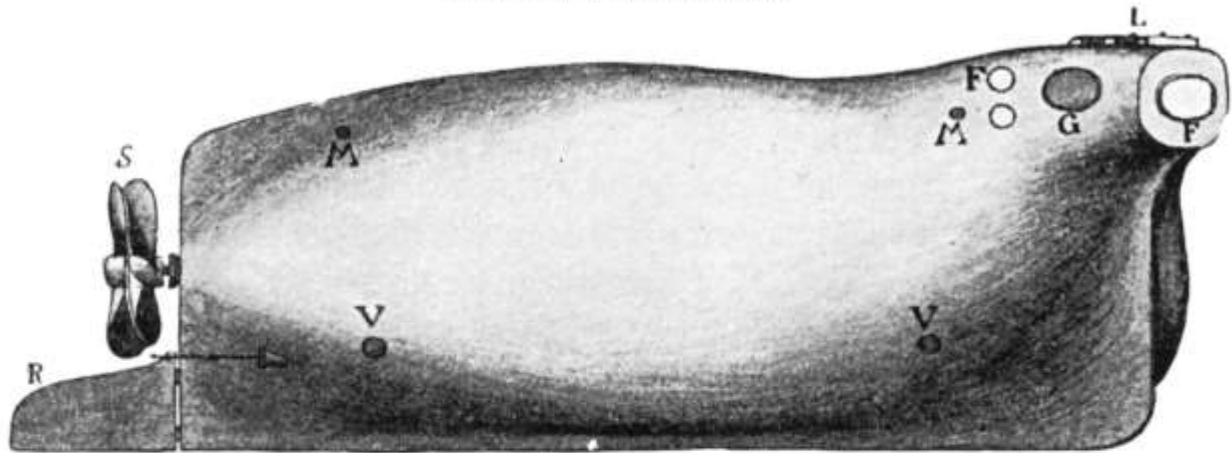

Äußere Ansicht.

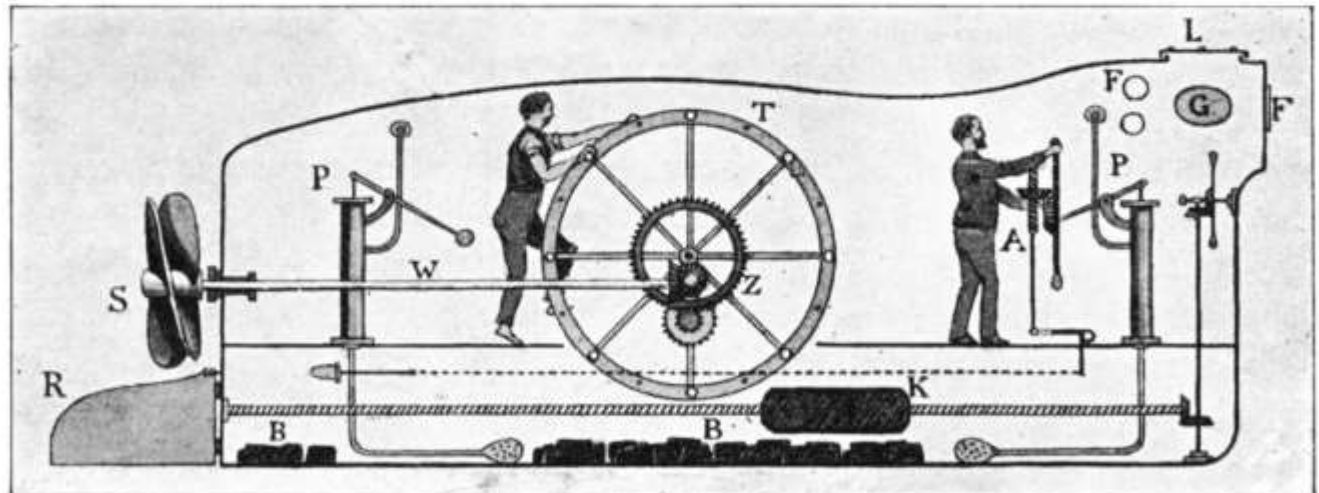

Das Innere, von der Seite gesehen.

### Der Bauersche Brandtaucher.

Länge: 7,90 m. Breite: 2,00 m. Höhe: 3,00 m.

- S Archimedische Schraube.
- W Schraubenwelle.
- R Steuerruder.
- A Steuerapparat.
- T Treträder.
- Z Zahnradsystem.
- P Pumpen.
- K Verschiebbares Balanciergewicht.

- B Eisenballast.
- V Ventile für das einzulassende Wasser.
- M Öffnungen für das auszupumpende Wasser.
- F Mit Glas verschlossene Fenster.
- G Mit Gummi verschlossene Öffnung zum Hinausgreifen, um Sprengminen an den feindlichen Schiffen zu befestigen.
- L Einsteigelufe.

*Sketch of the Brandtaucher (from an 1896 book)*

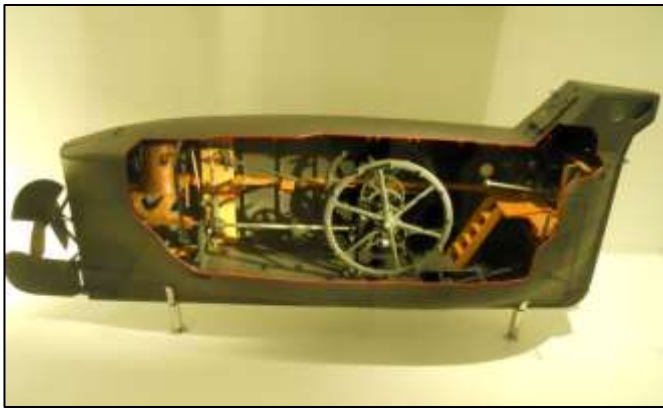

*The cutaway model in Dresden, Germany*

Bauer escaped by letting in water, thus increasing the air pressure, which allowed Bauer and his two companions to open the hatch. They floated to the surface in large bubbles of air escaping the submarine. This was the first submarine escape to be witnessed and reported.

In 1887 the wreck was discovered, and it was raised on 5 July 1887. *Brandtaucher* was first placed on display at the Naval Academy in Kiel and then in 1906 it was moved to the *Museum für Meereskunde* in Berlin. From 1963 to 1965 it was restored in the DDR at Rostock, and placed on display at the Nationale Volksarmee Museum in Potsdam.

The boat can now be viewed at the *Militärhistorisches Museum der Bundeswehr* (German Armed Forces Museum of Military History), in Dresden.



*Wilhelm Bauer*



*3ds max 8 model software for \$ 99.00*

The filmmaker from Kiel Zoran Simic described in his film "Submarine Ingenieur", the life and work of Wilhelm Bauer, and also the principles upon which he built the "Incendiary diver". In many 3D graphics sequences he illustrates the functioning of the submarine. On 3 February 2008 the 57-minute version of the film "Submarine Ingenieur" was shown in the local cinema, in the event centre KoKi, in Kiel.

In 1941 German director Herbert Selpin directed a biopic about Bauer with the title *Geheimakte W.B.1* (*Secret file W.B.1*; W.B = Wilhelm Bauer), which was released in 1942. It was a propaganda movie to further the submarine war. The plot was built on the novel *Der Eiserne Seehund* (*The iron seal*) from Hans Arthur Thies, published in 1941.

#### References

1. Elliott, David. "A short history of submarine escape: The development of an extreme air dive". *South Pacific Underwater Medicine Society Journal* 29 (2). Retrieved 2009-09-21.
2. Richard Compton-Hall (1984). *Submarine Boats: The Beginnings of Underwater Warfare*. New York: Arco Publishing. ISBN 0-668-05924-9.
3. Eberhard Möller, Werner Brack (2002). *Enzyklopädie deutscher U-Boote. von 1904 bis zur Gegenwart (The Encyclopedia of U-Boats. From 1914 to the Present.)*. Stuttgart: Pietsch Verlag Stuttgart.
4. Robert F. Burgess (1975). *Ships Beneath the Sea: A History of Subs and Submersibles*. USA: McGraw Hill. p. 238. ISBN 0-07-008958-2.

*Frank*

*Frank Landrus, IPMS 35035  
Proud IPMS NCT member since 1985*



# The Polynin Raid....

## Four Years Before the Doolittle Raid

Compiled by John Walen



*Chinese Nationalist Air Force SB-2M*

Four years before the US provided covert assistance to the Nationalist Chinese in the form of the American Volunteer Group (AVG), the legendary "Flying Tigers," the Soviet Union provided aircraft and volunteer aircrews in the form of the Soviet Volunteer Group (SVG). This military assistance was sent at what was arguably the most crucial period of the Sino-Japanese conflict.

Following the outbreak of the Sino-Japanese War in 1937, China's air arm was quickly decimated, and the Chinese Nationalist Government sought help from the major aviation powers. The United States equivocated in its response, but the Soviet Union quickly extended aid to China's air force. In the interest of its own security, Russia wanted to divert the attention of the Japanese from the Soviet Far East by tying them down in central China. At the same time Soviet flyers could gain combat experience and become acquainted with Japanese air warfare tactics. Moscow sent aircraft, volunteer pilots, and maintenance personnel.



*SB-2 being prepared for deployment*



*TB-3 in Chinese Nationalist Air Force markings*

Soviet airmen engaged the Japanese in aerial combat above China's major interior cities, bombed and strafed Japanese river and coastal shipping, attacked Japanese airfields in China, and made forays against targets on Taiwan. The Japanese, in turn, attacked Russian air bases in China. By the time the undeclared war in China's skies ended for the Russians in 1941, Moscow had sent hundreds of planes and Russian pilots who had actively participated in the hostilities.

Beginning in October 1937, some 450 Soviet pilots and technicians assembled at Alma Ata in the USSR to fly 155 fighter aircraft, 62 bombers, and 8 trainers into China. By 1941, Russian aircraft sent to China would amount to 885, including many two-engine (Tupelov SB-2) and even a few four-engine (Tupelov TB-3) bombers. Of the aircraft supplied, approximately half were turned over to the Chinese Air Force and half were flown and maintained by Russian personnel. The SVG units were stationed at airfields near the cities of Nanjing, Hankou, and Chongqing, and at Lanzhou in China's northwest at the terminus of the Russian supply route. One of the most daring and audacious actions of the SVG was a daylight attack by Tupelov SB bombers on a heavily defended target considered by the Japanese as part of their homeland.



*SB-2 bomber at Kunming evidently being inspected by member of AVG*





*SB-2M after crash landing in Mongolia*

The commanders of the SVG wanted a dramatic operation to commemorate the 20th anniversary of the Red Army, a mission that would stretch airmen and aircraft to the very limits of their capabilities: an attack on the main Japanese airbase on Formosa, 100 miles off China's Fujian coast. The raid was a daring undertaking for the 1930s, and more than likely to fail. Against all odds, it succeeded.

At the beginning of February 1938, the Chinese high command learned that the Japanese were in the process of massively expanding the main airbase complex on Formosa. Huge containers of aircraft assemblies were regularly being sent to the island. Planes were being assembled on the base and readied for operations around Shanghai. Many aircraft were, in fact, already complete.

China's limited air strength at the time would make it difficult to counter this major expansion of Japanese airpower after it became operational. But a pre-emptive strike might eliminate or greatly reduce the threat, if such an action could be mounted quickly.

The Chinese command thus turned to its only available force capable of such an operation, the Soviet Volunteer Group in China. Twenty-eight (28) Tupelov SB-2 bombers were designated to fly the mission and the mission was to be commanded by Captain Fyodor Polynin. The distance from Hankou to Formosa was more than 650 miles, so the target was barely within the range of the twin-engine SB-2 bomber.



*SB-2M located at the Russian Air Force Museum, Monino, Russia*



*SB-2 Cockpit*

The SB-2 was a fast bomber for the mid-1930's and contemporary Japanese fighters were not able to catch it, let alone outrun it. So, while the mission was risky, the potential damage and psychological effect justified the attempt. The Japanese airbase was ringed by mountains, hard to approach, and defended by fighters and numerous anti-aircraft artillery units. At that stage of the conflict, Russian bomber crews had ample combat experience and were used to flying without fighter escort.

Captian Polynin decided to fly at 13,500-16,500 feet to extend the range of the SB. The crews would suffer from anoxia in the course of the long flight, since there were no oxygen masks available, but there was no alternative. The bomber group would pass the island to the north and then turn south to give the impression that they might be Japanese aircraft flying down from southern Japan. The bomber group would then bomb the target and head for the coast. On the way across the strait, the bombers fly at 12,000 feet. They would land at a coastal airstrip for re-fueling and then return to Hankou.

As the day of the raid approached, February 23, security was tight. To deceive Japanese spies at Hankou, word was spread among the Chinese personnel on the airfield that the squadron was preparing to bomb Japanese ships on the Yangtze River near Anqing.

Early on the morning of the raid, the silence of daybreak was broken by the sound of air-raid sirens. Dark dots appeared on the skyline, and the distant sound of Japanese bombers was heard. Two groups of nine airplanes were visible against the amber sky. It appeared that the Japanese bombers were heading for the Hankou airbase.



*SB-2 ©1998 by Robert Craig Johnson*



*SB-2*

There was no time to take off or disperse the bombers across the airbase. If the Japanese bombers attacked the armed and gassed aircraft, the mission would be doomed. Then, as suddenly as they had appeared, the Japanese turned and headed for Changsha. In a couple of minutes, they were gone. Why the Japanese planes passed by the Hankou airbase is still a mystery.

At 0700, a signal rocket started the heavily laden bombers on their raid as they took off one by one and vanished into the clouds. At 16,000 feet, the bombers lined up in column and headed for Formosa, flying above the clouds. The first symptoms of anoxia—rapid pulse, dizziness and sleepiness—soon appeared. The planes passed the Yangtze valley and lake Poyang Hu. The clouds became sparse. After another hour of flight, the planes flew past Fuzhou, the last Chinese city en route to Formosa.

A quarter of hour later, they saw the coast of Formosa in the distance. As planned, the bomber group flew north of the island and then turned south. Thick clouds, driven from the tops of the mountains by the sun, were now covering the ground. Polynin was faced with a crucial decision: drop their bombs from above the clouds and hope for the best or descend through the clouds hoping to avoid the mountains near the airbase. Fortunately for the Russians, a large opening in the clouds appeared ahead of the bomber formation. Polynin headed for the opening with the rest of his formation close behind. The bombers reduced speed and began to dive.



*Soviet aviators at Hankou airfield*



*SB-2M ©1996 by Robert Craig Johnson*

The crews were on edge. Everyone was waiting for fighter attacks and anti-aircraft fire. The gunners scanned the sky for enemy planes, but there were none. The anti-aircraft guns remained silent.

Apparently, as anticipated by the mission planners, Japanese ground observers assumed the formation of bombers coming from the north would be Japanese. The main Japanese airbase looked impressive. The combat-ready planes were lined up in two rows. Hangars and huge white fuel tanks were stretched along the opposite side of the base. Large grey boxes of aircraft assemblies were everywhere. The Japanese had made no attempt at camouflage or dispersal. They seemed sure of their safety.

The lead group of bombers dropped their bombs from 10,000 feet and hit the Japanese aircraft in the center of the airfield. Other groups attacked the hangars, stores and fuel tanks. Secondary explosions blew the fuel reservoirs apart. In all, the Soviet planes dropped two hundred and eighty bombs.

The Japanese anti-aircraft artillery began to fire near the end, but too late. The now much lighter SB bombers had already turned and headed for the Taiwan Strait, running flat out for the Chinese coast. The refueling strip at Fuzhou was narrow and confined by mountains and swamp. However, all bombers landed safely and ground crews refuel the planes.

The bombers had been in the air for more than seven hours when they returned to Hankou.



*Tupolev SB on display at Monino Air Force Museum  
The only known survivor of some 7,000 aircraft*





*From left to right: AA Shumejko, FP Polynin, GA Ivanov*

Word of the successful raid quickly spread among the local inhabitants. On the way from the airfield the Russians saw large crowds of celebrating people in the streets. The war was going badly for China, the Chinese army was retreating from a series of fiercely fought and bloody defeats, so the successful raid was reason enough for the joy and enthusiasm.

News of the raid on Formosa was headline news in Chinese newspapers. The raid was a shock for the Japanese. The airbase was out of action for a month. According to Chinese intelligence, about 40 planes were completely destroyed and a large number damaged. A number of unassembled planes were also destroyed in their shipping containers. Several hangars and thousand gallons of valuable aviation fuel had been destroyed. The Japanese government recalled the military governor of Formosa, and the airbase commander was court-martialed and subsequently committed suicide.

As the Soviet government had increased the Chinese Air Force's ability to resist the Japanese in the air and boosted Chinese morale, American consular officials, attachés, and air advisers in China became concerned over the possible political consequences of the Russian aid.

The Americans welcomed the Russians' efforts to counter Japanese aggression, but at the same time they expressed apprehension that Moscow might gain a dominant position in Chinese aviation.



*SB-2 in Chinese Markings*



*General Fedor Polynin*

When the war in Europe forced the Soviets to withdraw most of their advisers from China, the Chinese government increased its efforts to secure American aid. The Chinese Nationalist government petitioned Washington officials for support, and Claire L. Chennault and Chinese agents were dispatched to the United States to provide the military expertise and equipment for the campaign. These efforts resulted in the formation of the American Volunteer Group.



*Tupolev SB-2M100 National China  
©2004 Sergey Ignat'ev*



*Tupolev SB-2M100A National China White 27 1939-0A  
©1996 by Robert Craig Johnson*

# Tupolev SB-2 Kits

Currently, available kits of the SB-2 are all 1/72 scale releases...but look for a detailed, injection-molded 1/48 scale kit release early next year.

## ICM 1/72 Kits



*ICM 72161 1/72 Tupolev SB 2M-100*



*ICM 72162 1/72 Tupolev SB 2M-100A*

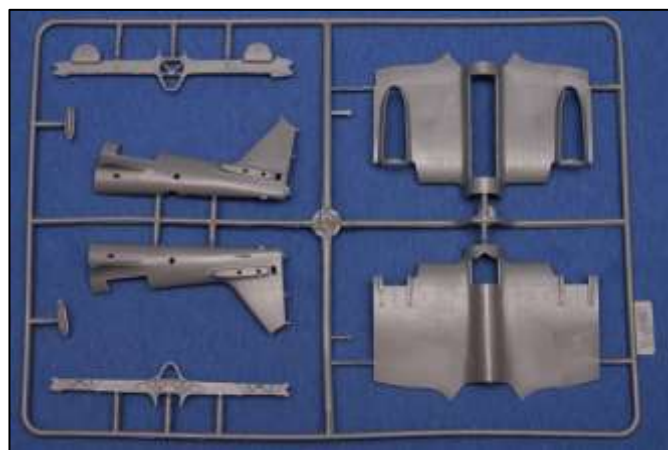
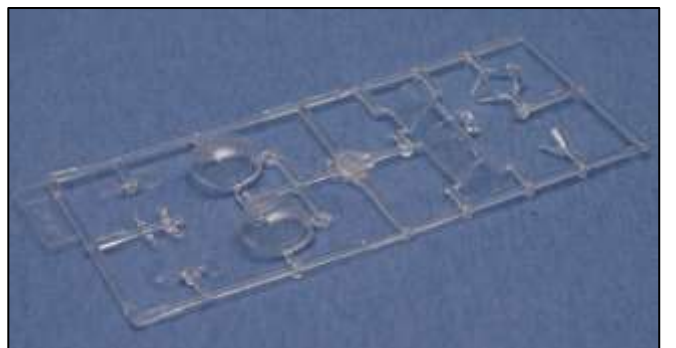
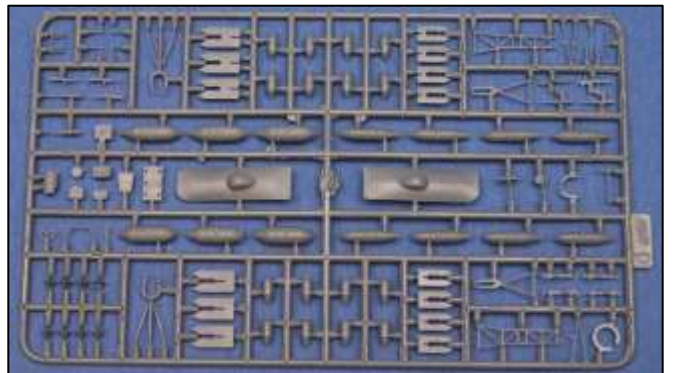
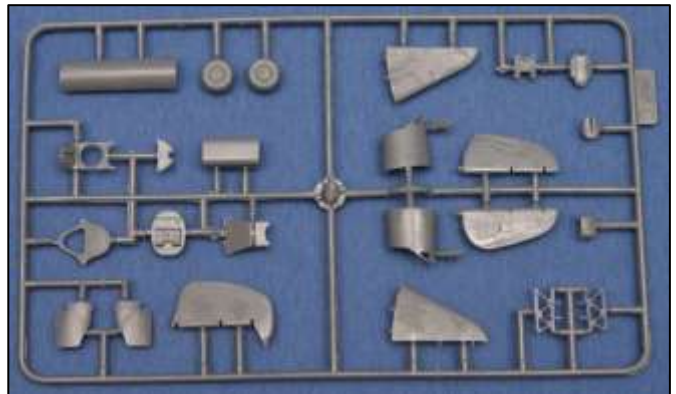
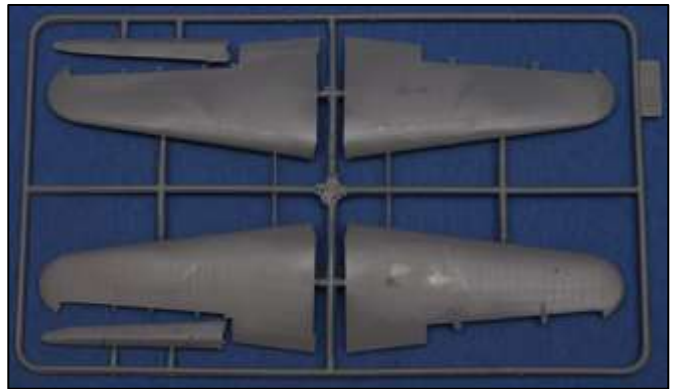



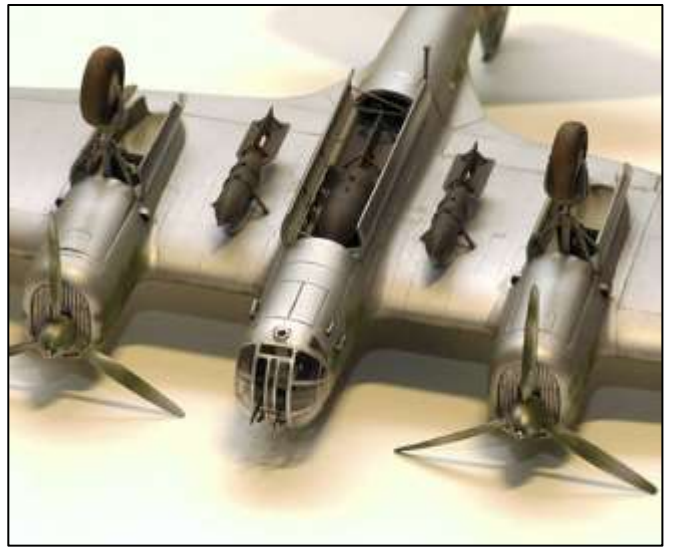

*Model built by Jiri Kure (HyperScale)*



*Model built by Jiri Kure (HyperScale)*



*Model built by Jiri Kure (HyperScale)*



*Model built by Jiri Kure (HyperScale)*



*Model built by Jiri Kure (HyperScale)*



*Model built by Jiri Kure (HyperScale)*



## MPM 1/72 Kits

The 1/72<sup>nd</sup> MPM kit is a bit cruder than the ICM kit, however, if you want the later version with the streamlined nacelles and the dorsal turret, it's your only real choice.



*MPM 72046 1/72 Tupolev SB 2M-100/B71*



*MPM 72047 1/72 Tupolev SB 2M-103/Bis  
VVS, Finnish, Chinese markings*



*MPM 1/72 Tupolev SB 2M-100A  
Model by Uwe Borchert*



*MPM 1/72 Tupolev SB 2M-103/Bis  
Model by James Gray (HobbyVista.com)*



*Image from Ice Flake Studios (Iceflakestudios.com)*



*MPM 1/72 Tupolev SB 2M-100  
Model by Václav Lomitzki (HobbyVista.com)*



# FROG based 1/72 Kits



*Frog 1/72 F176 Tupolev SB-2 :Katyuska”  
Initial release in 1969*



*Frog 1/72 F176 Tupolev SB-2 :Katyuska”  
1974 Rebox*



*Novo 1/72 F176 Tupolev SB-2 :Katyuska”  
1978 Rebox with German decal option*



*Novo 1/72 F176 Tupolev SB-2 :Katyuska”  
1979 Rebox with a change in decals*



*Eastern Express 1/72 72260 Tupolev SB-2, 1990s*



*Ark Models 1/72 72002 Tupolev SB-2, 2000s*



*Chematic 1/72 Tupolev SB-2*



*Zabawka 1/72 Tupolev SB-2*





*Novo 1/72 F176 Tupolev SB-2 "Katyuska" fuselage*



*Novo 1/72 F176 Tupolev SB-2 "Katyuska" wings*



*Novo 1/72 F176 Tupolev SB-2 "Katyuska" stabs*



*Novo 1/72 F176 Tupolev SB-2 "Katyuska" gear*



*Novo 1/72 F176 Tupolev SB-2 "Katyuska" decals*



*Frog 1/72 F176 Tupolev SB-2 ©2005 by Brian Baker*



*Frog 1/72 F176 Tupolev SB-2 ©2005 by Brian Baker*



*Frog 1/72 F176 Tupolev SB-2 ©2005 by Brian Baker*



# MPM 1/48 Kits



MPM 48021 1/48 Tupolev SB-2M 103/Bis

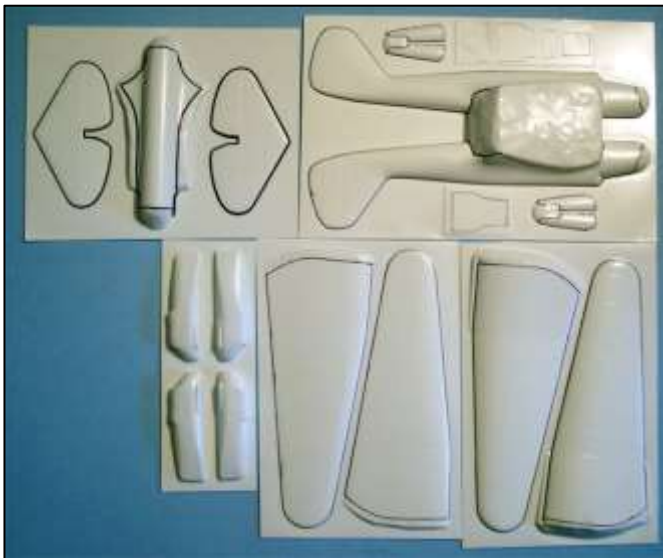

MPM 1/48 Tupolev SB-2M ©2003/2004 by Matt Swan



## Xuntong Model 1/48

Xuntong Model has announced a Tupolev SB-2 series on their website: [www.xtmodel.com.cn](http://www.xtmodel.com.cn). We can be expecting a SB-2-100, a SB-2-100A, and a SB-2-M103 sometime in late 2014, or probably 2015.



*Xuntong Model B48006 1/48 SB-2-100 CAD*

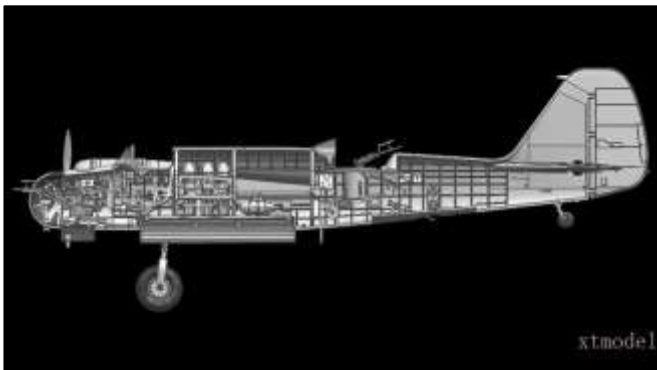

*Xuntong Model B48007 1/48 SB-2-100A CAD*

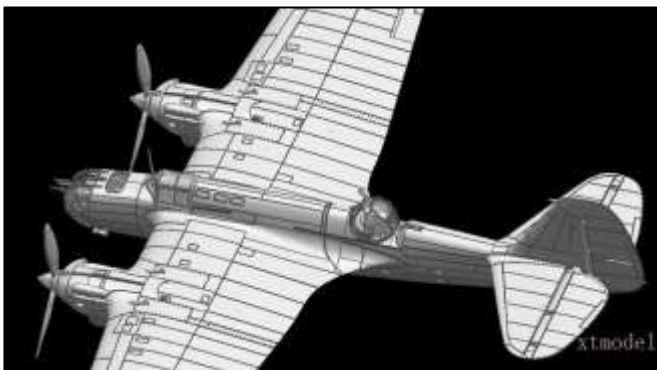

*Xuntong Model B48008 1/48 SB-2-M103 CAD*

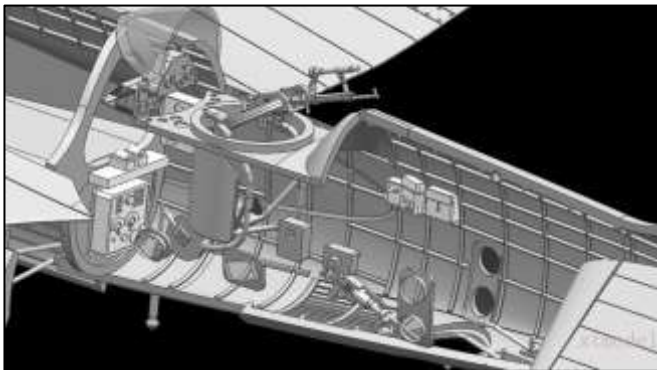

*Xuntong Model B48006 1/48 SB-2-M100 CAD*



*Re-issued by Squadron who recently had it on sale for \$4.54*

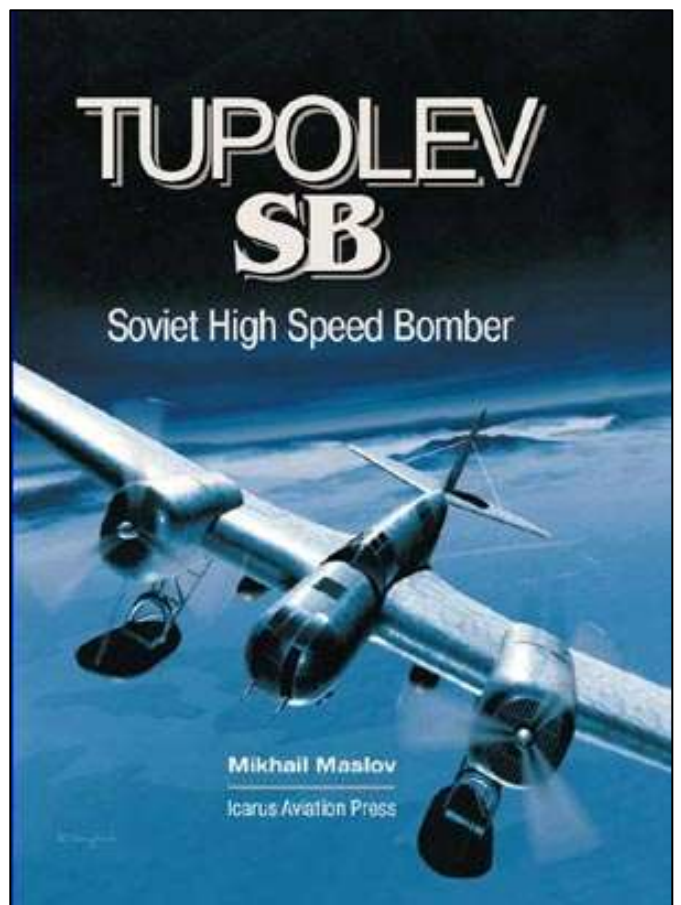

*Icarus Aviation Press – on sale now for \$ 25.00*

### Tupolev SB-2 Internet Video Links

Russian WWII documentary film with interesting walk-around, detail sequences -

<https://www.youtube.com/watch?v=Sk-X1eIJVD4>

Short pictorial tribute consisting of of documentary footage and stills -

<https://www.youtube.com/watch?v=kjMV3PLBfV0>

*John Walen*

*John Walen, IPMS 17482*

*Proud IPMS NCT member since 1982*



# Walen's Kit Pick of the Month Alliance Modelworks

## La Langosta

1/144 Steampunk Coastal Submarine



Normally Alliance ModelWorks makes tanks, warships, figures (people) that sort of things. Lately, they have started to venture into fantasy subjects, and they're planning to come out with a series of pirate themed steampunk vehicle models. The first one on their list is this small submarine, shaped like a lobster.



*body (most of it) roughly put together, without gluing.*

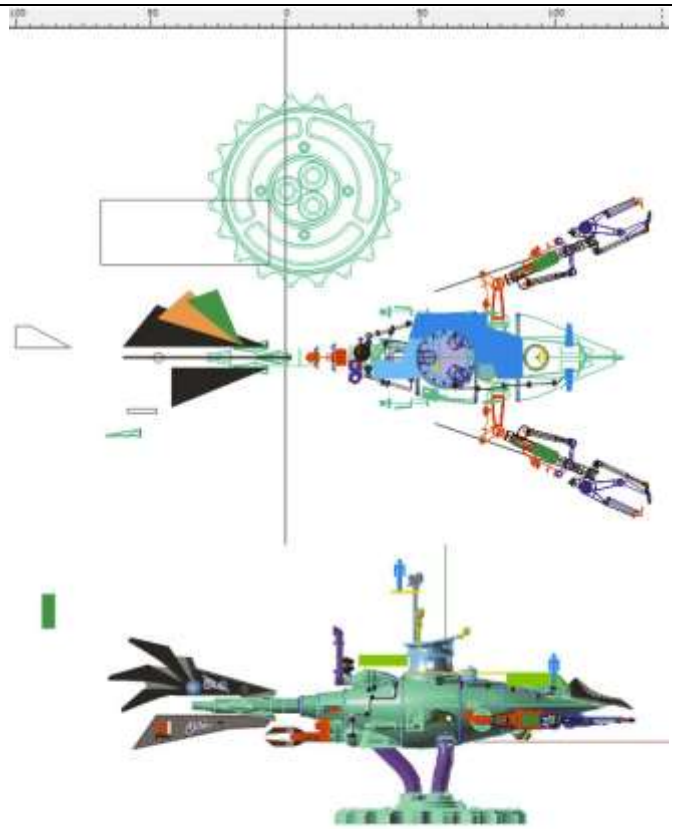

*drawing board*

To actually build the model would require some superglue and small tweezers. The submarine is ~20cm long, in 1:144 scale (so it would be around 30 meters long if it was 1:1).

It will come with a lot of photo etched brass parts that are easy to work with. There will also be decals and other necessary components to finish the kit into a display model.

The lobster was just first of the series of steampunk vehicles. All will be in 1:144 scale, they are meant to be finished into desktop displays.

Do you like Steampunk? Check out this you tube video link: The Battleship Barnum's Dream:

<http://www.youtube.com/watch?v=k-1MEVqE4wE>





## FW001 1:144 Steampunk Submarine

- Approved by the Association of Elves and Gnomes
- Digitally patterned resin hull
- Photoetched brass details
- Machined brass mast
- Waterslide decals
- Display base
- Easy construction
- Have fun painting it!
- MSRP \$ 95.00

<http://www.am-works.com/>



1:144 Steampunk Coastal Submarine  
FW001

AM Works

Naval Department of Cybertekno Marine Classification  
Coastal Salvage Submarine C05

MSRP \$95.00

I.R. Illuminator

Periscope

Auxiliary water jet

Optional

Towing hook

Buster: Three thousand  
Launched: 1885  
Length: 300'  
Beam: 20-30' (pressure hull)  
Draft: 20'  
Displacement: 150 tonnes (1400000)  
Power: 5.000000 Diesel/Electric  
Submerged: Electric Motor  
500 HP

Chief Designer/ Weapons:  
Louis Gathmann

[Http://alliancemodelworks.com/](http://alliancemodelworks.com/)

Alliance Model Works

P. 1



1:144 SteamPunk Coastal Submarine FW001

Forward Port (shown): Alpha Bow  
Electric Drive and Coupling - Mermaid Lamp

Optical Periscope  
Piezoelectric transducer hydrophone  
Integrated infrared illumination  
Long range radio

Optional Radio Antenna

Machined brass antenna mast

Map fold this section

425MPa class high tensile strength Bethlehem steel  
Double hull, internal chain diving tank  
Pressurized conning structure  
27 Hydroplane assisted dynamic diving  
Maximum diving depth 1,300m

Alliance Model Works  
© 2012 All rights reserved.

P. 2

<http://alliancemodelworks.com/>

1:144 SteamPunk Coastal Submarine FW001

Air harpoon capable of firing high explosive projectiles  
2x 18 inch torpedo tubes  
4 round oxygen driven high explosive torpedoes  
Maximum range 3200 yards

Spare parts:  
B1+A1 Nameplate  
A25 Fighting rods  
A26 Davits

Optional Harpoon gun

Lead Consultant: Nikola Tesla

Alliance Model Works  
© 2012 All rights reserved.

P. 4

<http://alliancemodelworks.com/>

Available from spruebrothers.com for \$ 84.99

# Walen's Model Pictures of the Month



The following set of pictures appears on <http://dqscaleworks.blogspot.com>. The model was built by Ricardo Rodriguez who resides in Spain and his models appear periodically on Diego Quijano's scale model blog. Diego resides in the Canary Islands.

Ricardo used the Accurate Miniatures 1/48 Sturmovik kit as a base to produce one of his unique creations. He removed the panel lines and rivets of the wooden surfaces, engraved the rivets and lines in the metallic pieces and modified the service hatches.

The metallic zones were painted with Alclad paints and the wooden surfaces were imitated with airbrush, brushes and pencils.

In his own words: *"...my approach was very conceptual. The model is painted in the colours of the basic materials in which each part was made. It is like a display of how surprising a mixed construction plane can be, from the perspective of engineering."*





*“There is steel, duraluminium, plywood, and fabric, but not in any way that could be actually seen in the real plane -either under construction or debris- but in a figurative way.”*

*It lacks of priming, fabric cover on the wooden surfaces or pieces that were painted before the assembly in the factories. The colours of the metallic surfaces don't represent the real material but the thickness of the armour in each zone. I painted the interior following the ordinances, something that never happened at that time when there were common the primed pieces and bare materials.”*

Next month I plan to include another of Ricardo's models... a 1/72 jet aircraft.





**IPMS NCT Member Bonus Feature!**  
**Soviet Storm: WW II In the East**  
**The Air War**  
**Episode 12 (of 18)**  
(Link's By Walen)



On 22 June 1941, German pilots were the first to see the run rise. Before the day was over, the Soviet Air Forces had lost almost 2,000 aircraft. The early German air superiority gave a significant boost to German confidence, and severely damaged the Russians. The air wars over Russia between the Soviet Union and Germany would be some of the biggest and toughest in military history.

This is one of my favorite episodes, loads of great CG flying sequences and new B&G footage. Play close attention to the sequence where the six La-7s attack 32 FW-190s near Berlin.

Bing.com version...good large screen image, but includes commercials...

<http://www.bing.com/videos/watch/video/the-air-war/17w24ml27>

You Tube version...large screen image not as good, but no commercials...

<http://www.youtube.com/watch?v=EmgCaaSTJ9A>



**September 2014's**  
**Mystery Planes**  
**Can You ID This Aircraft?**  
**John Walen**



**Check the Next Issue of the FlakSheet!**

**Last Month's Mystery Planes**



*PZL 30*



*Lavochkin LaGG-3 in Japanese markings (Plane flown to IJAF base by Russian defector)*



*A little model humor...*

## 30 Years!!!!!!

Hard to believe three weeks have already passed since the Nationals. I managed to get the 1/48 Curtiss SOC-3 Seagull kit finished in time and take a dozen with me. They were sold out in the first two hours Thursday morning.

The next items to be completed will be the 1/48 RB57A conversion and the 1/48 Felixstowe F2A flying boat. The RB57A conversion should be available in late August.

### Like Lone Star Models on Face Book.

Note there are two Lone Star Models on Face Book. One is an RC hobby shop in Lancaster Texas. Mine has my logo on it and a photo of an LSM B-10 built by Chaz Bunch.

NOTE!!! Any prices shown in this news letter do not include S&H. or Texas sales tax of 8.25% (Texas residents only). Pay Pal accepted. Please use **LSMODELS@PDQ.NET** for the Payee.

PS. If responding to this News Letter, PLEASE!! Omit it when you write to me. Don't include it as part of your e-mail. I wrote it, I do not need to read it again.

Feel free to share this news letter with your friends. I can add them to the mailing list.

Thanks!

[www.lonestarmodels.com](http://www.lonestarmodels.com)



### Miscellaneous New Items

**NEW!** 1/48 Curtiss SOC-3 Seagull resin kit. White metal prop and struts; no decals. \$65.00

Due to the number I need to make right now and that I am waiting on a production mold to be made for the metal parts, I have currently listed this kit as SOLD OUT. I have enough metal parts on hand for some orders and I am working on those now.



*1/48 Curtiss SOC-3 Seagull*

**NEW!** 1/48 Martin B-26 Marauder cockpit set. \$25.00 Note in the photo below, the pilot's seat, instrument panel and controls have not been installed



*1/48 Martin B-26 Marauder cockpit*



### *1/32 5"-51 Shore Battery*

I have a number of things other than aircraft I want to do. I have long had an interest in the battle for Wake Island. To that end I wanted to build a model of one of the 5"51 shore batteries. Below is a photo of the model masters as they are right now. It will just be the gun, some loose ammo and some transport containers for the powder bags.



*1/32 5"-51 Shore Battery*

The 1/48 Felixstowe F.2 flying boat kit and 1/48 Martin B-57A Canberra conversion will be coming out next.

I still have three 1/192 ship hulls I never did complete. I am now thinking about finishing them as well. They are the ironclads U.S.S. New Ironsides, U.S.S. Roanoke, and the Peruvian Monitor Huascar.

Pay Pal accepted Please use  
**LSMODELS@PDQ.NET** for the Payee.

**NOTE!!!** All prices shown do not include S&H or Texas sales tax of 8.25% (Texas residents only)

## **Review**

### **Dragon Black Label M6A1 Heavy Tank 1/35 scale #6789 (Smart Kit)**

It may surprise some of you that at one time almost all I built was armor. Mind you, 90% were conversions or scratch builds.

Since I have been on the sidelines of the new armor releases I was not aware of the number of new and interesting kits that have come out in the past few years. Some years ago I had purchased the DML Maus Heavy Tank and partially assembled it. Recently I became aware of how many of the super heavies are now out in plastic kits. So many that I've decided to build a 5 or 6 vehicle collection for an entry in the IPMS model competition next year at the Nationals.



*Note all of the attachment points that must be lined up to add the skirts*

While cruising the other vendor tables at the most recent IPMS Nationals in Virginia I spotted a new (to me at least) kit. The Dragon M6A1; sort of a Sherman on steroids. I could not resist!

The kit consists of 257 parts in the usual light grey styrene that DML/Dragon uses. 140 of the parts are just the road wheels and their supports! (one of the flaws in my planned project is the huge number of road wheels on the Super Heavy tanks )

The tracks are in a light salmon color and made of a soft flexible material labeled DS on the parts layout. They come in four lengths with tabs to connect the ends.

Over all, the kit looks to be very accurate. Being that the turret was a casting the surface texture is smooth and might benefit from some roughing up. The box top says the turret is a one piece slide molded part, it does not look to be and it is in two main pieces not one. Just a minor point though.

My biggest gripe with this kit and one that may give you fits too is the suspension assembly. The axles for the road wheels on the suspension arms could have been made longer, it would make assembly a lot easier. As they are in the kit, they are barely long enough to hold the wheels in place.



*DML 6789 1/32 M6A1*



*See how poorly the wheels line up? I gave up trying to get them to cooperate so I would not break anything*

You have to assemble 140 parts into 16 wheel truck assemblies. There are 4 different styles of arms and it took me a few minutes to sort this out.

When I got several assembled and installed on the model I discovered they do not fit/line up very well. Most of this is due too flimsy of an assembly design.

The M6A1 has large armored side skirts and to install them you must line up around 30 different points on each side of the hull with these plates! All of this also helps to make the suspension alignment even more difficult to maintain.

Fortunately the skirts and the wide tracks had a lot of this once fully assembled. I threw out the instructions for the road wheel/skirt assembly and made it work after trying it their way.

Other than the suspension issues there are few other problems. There is however a full length sink mark that runs the length of the lower upper hull sides on both sides of the hull. It is not too deep but if not filled it will be noticeable under your paint.

The paint scheme is simple, Olive Drab. I recommend the OD sold by Testors, It has a good faded look to it.

Price: I paid around \$75.00 for it I believe at Free Time Hobbies at the Convention. It was a new kit to me, the copyright date on it says 2014 so I assume it is still readily available.



*M6A1*



*A7V*

## Making Rivets

This has never been a fun task. There are many ways to do this on a model. All are time consuming some may be considered a bit crazy? As an example of the later, I scratch built a 1/35 A7V German World War One tank many years ago. There were no aftermarket things I could use to represent the thousand or so rivets. I remembered that in my High School Biology class we had to make an insect collection.

We used some very thin pins that had smaller heads than a regular sewing pin did. So I purchased thousands of insect pins and one day with an empty model kit box in my lap I cut the pin off of every one of them! I left a short bit of the pin attached. After I built the model I primed it in Floquil grey primer and laid out the lines for the rivets. I then hand drilled each hole using a small battery powered hand drill . Unfortunately Xacto no longer makes these.

I then super glued each one in a predrilled hole. It was well worth the effort. The model won a 1st place in the Scratch built Armor class at the Nationals.

Today some modelers use a pounce wheel to emboss the rivets on but I have never been too happy with the results when I tried it.

What I like to use are Archer Fine Transfers 3D rivet decals. They are also tedious as are any of the other methods but , and that is a big but in my book, if you make a mistake with them there is no scribed line or series of holes to fill. Just wet them and reposition them. You apply them like other decals but first I suggest that you prime the model and lightly draw on some lines to follow. Then a coat of gloss, the rivets and followed by a final coat of gloss and your paint.

Till next time, remember to follow Lone Star Models on Face Book too. I think the term is "Like" us?

*Mike*

[www.lonestarmodels.com](http://www.lonestarmodels.com)





*Transmuting*

*Fe to*

*Au*

**By Patricio Villarreal**

## **MPC 1/42 Incom T-65 X-Wing Fighter**



I bought this vintage 1978 MPC kit at Scalefest a few years ago on a hunch I would build it one day. I started this build July 7 and as of yesterday, Aug 24 (7 weeks), it is COMPLETED.

This is a very difficult kit to build and not for beginners. There were major fit/alignment issues and the parts needed multiple 'massagings' to coax it into position. I am not a Star Wars fanatic so the accuracy of this kit is probably way off any technical drawings George Lucas' creative minds came up with. But since it's science fiction I added my imagination to it as well.



Paints used are Testors, Model Master, Alclad II, Tamiya clears & Vallejo Acrylics. The decal sheet is 36 years old so I decided to not use it. All the markings are painted on and there are NO decals on this build.

The laser blast tubes on the wingtips were poorly molded so I decided to scratch-build those. I used brass tubing, plastic tubing, paperclip wire & round sprue pieces to make it look right.

The torpedo chute exits on the lower side of the fuselage were represented by panel lines. Using leftover brass tubing I scrapped off the plastic to obtain the faired look. During the scraping process I dug through the plastic and had to install plastic card to create a wall for Milliput to attach to. The Milliput was used to smooth out the torpedo chute. Though you can't see it there is brass tubing installed to represent the torpedo exit.

The wing interiors where the 'holes' are, were blank. I wanted to add more detail and character to these areas so I added wire, I-beam sections and thin card stock.

There were some major injection mold tab circles in the engine intakes. Because of the size of the openings it was impossible to scrape off.

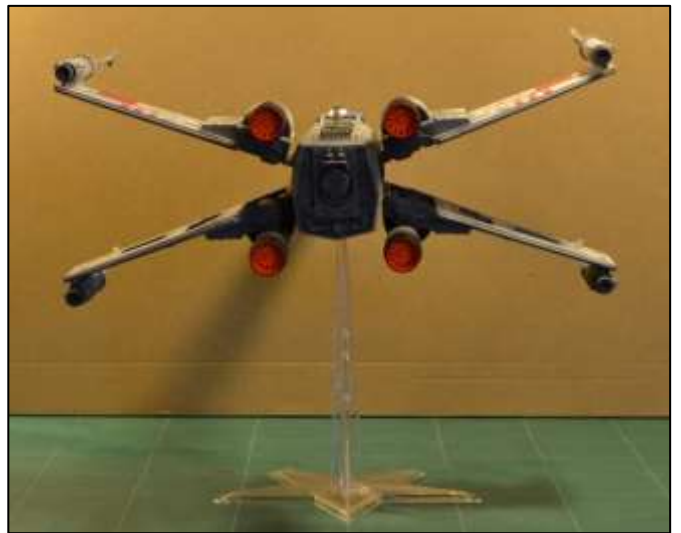



The only way to get rid of them was to cut the aft side of the intakes out and detail the interior engine since it would now be visible. Instead of doing this major undertaking I cut copper wire mesh and placed them in front as intake screens. Then I painted it flat black.

The molding for R2-D2 was extremely poor. The raised panel lines were not straight, overly stated...let's just say it was horrendous. I sanded the dome section smooth to get rid of all the raised detail and painted it with Alclad II polished aluminum.

To replicate the blue panels on the robot's dome I used Tamiya tape. With a hole-punch and a new X-Acto blade I cut the patterns of the blue panels based on images from the internet. After applying the tape I painted it Testors Flat Sea Blue. Then I applied several coats of Future acrylic floor wax to seal it. For the lenses, I hole-punched aluminum tape and tinted it with clear blue, yellow & red.

The kit pilot figure was really a race car driver with a full helmet; nothing like in the movies. Luckily I had recently built a Warhammer model and there was an extra figure head in the kit about the same scale.

I conducted a head transplant and used two-part epoxy (Milliput & Green Stuff) to reshape the torso and



molded a helmet on to the new head. The helmet lens is from a discarded clear drink cup topper from Sonic painted with Tamiya clear orange.

Paints used on the figure are Vallejo acrylics. Extra wiring was added to the cockpit around the seat and I added joystick handles to the pilot's hands since the kit had none.

The engine installation was very weak based on the kit instructions. To make sure they had 'staying power' I added paperclip wire to the attachment points for reinforcement.

Weathering was done using pre/post airbrush shading, silver/gold Prismacolor pencil and charcoal dust (black, white, sienna). Then an overall flat coat of Model Master Clear Flat Lacquer.

Overall I am satisfied with this build and I hope it shows. I learned A LOT on this build with scratch building and painting. Always learning, always improving...Enjoy the pictures.

*Pat*

*Pat Villarreal, IPMS 467836  
Proud IPMS NCT member since 2007*





## Floyd's Fling

# Lifelike Decals 1/72 Consolidated B-24 Liberator Pt.1 By Floyd S. Werner, Jr.

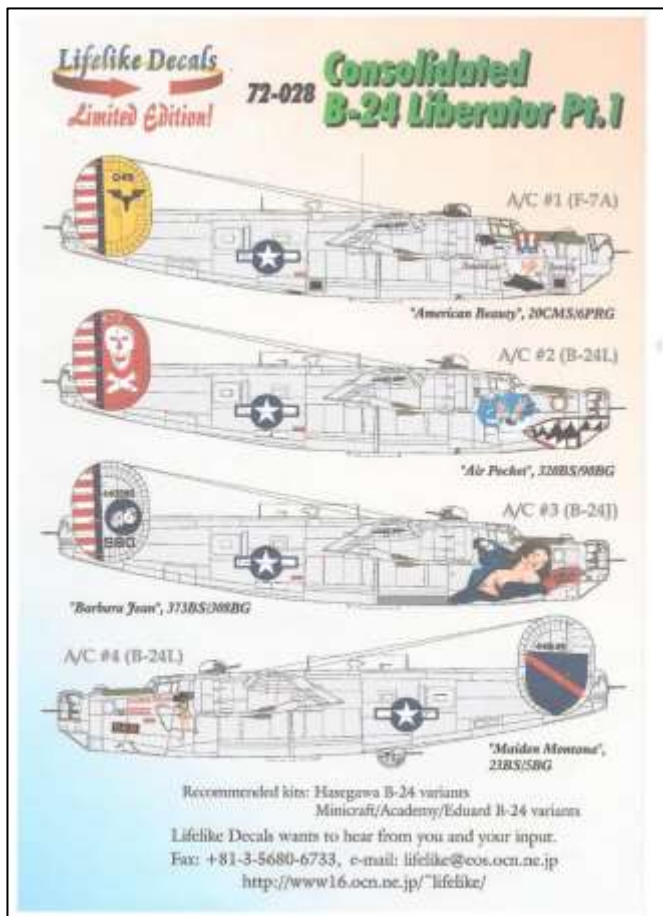

Product/Stock #: 72-028

MSRP:

Manufacturer Website:

<http://www16.ocn.ne.jp/~lifelike/72028.htm>

Provided by: Lifelike Decals

Providers Website URL:

<http://www16.ocn.ne.jp/~lifelike/>

Nose art! I love nose art and there isn't a much better canvas than the side of a B-24. The latest releases of decals from Lifelike brings the B-24 nose art to life. In Part 1 there is four aircraft from the Pacific Theater of Operations (PTO).

Packaged in a clear zip lock baggie, the decals themselves are printed by Cartograf and Microscale so you know they are some of the best in the world. The decals are printed on three sheets.



The actual nose art is printed by Cartograf. This allows for some finesse and shading that is quite realistic. The other markings and national markings are printed by Microscale. Both decal manufacturers are world known for their quality. The printing is very crisp and they will react well with setting solutions. All the decals are thin and opaque.

The instructions are printed in full color on two single sided A4 sheets. The best thing about the instructions is how Lifelike conveys how they came to the conclusions for the color call outs. Unlike other decal companies tend to think they are right, regardless. Lifelike takes a more practical approach and analyzes currently available information and then makes an informed decision. They acknowledge that they may be incorrect.

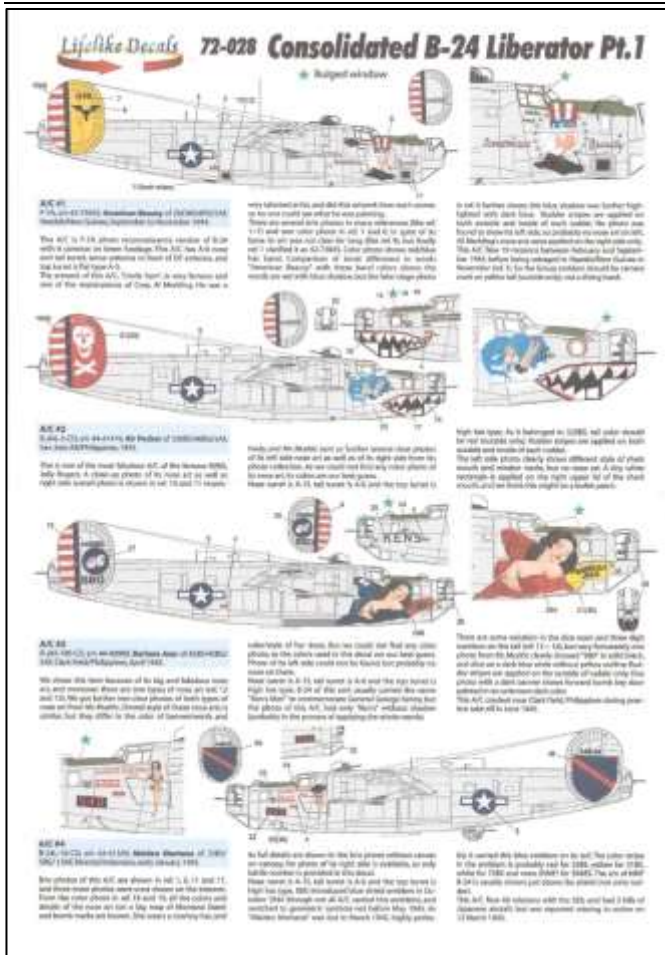

Sometimes they are wrong and they will offer replacement decals when they are. How many other decal companies do you know who do that? The last page contains the reference that Lifelike used to form their analysis.

The key of any decal sheet is what they offer. These PTO B-24s are some of the most colorful aircraft with tail markings and the pinup nose art.

The first aircraft is an "American Beauty" camera ship flying out of New Guinea in late 1944. The really unique look of this nose art is the inclusion of a nude in the profile of "Uncle Sam".



**"Air Pocket"**  
**B-24L-5-CO 44-41479, 5<sup>th</sup> AF, 90<sup>th</sup> BG, 320<sup>th</sup> BS**



**"Barbara Jean"**  
**B-24J-190-CO 44-40980, 5<sup>th</sup> AF, 43<sup>rd</sup> BG, 65<sup>th</sup> BS**

It looks more like a psychological test than nose art. The yellow vertical tails sets this apart along with the red and white striped rudder outlined in blue. Interestingly, Lifelike provides decals for the camera windows. It is a unique approach.

The second aircraft assigned to the 90BG has a large "Jolly Rogers" sharkmouth design as well as its large pinup nose art on a light blue background. The vertical tail has the Jolly Roger emblem but is on a red background this time. This aircraft also has the red, white and blue rudder.

The third aircraft, assigned to the 43BG, actually has two different nose art. The nose art is "Barbara Jean". Early on she has a blue dress and red banner. Later the dress is repainted red with a yellow banner. The left side has "Ken's" on the nose. The rudder has the red, white and blue rudder while the vertical tail has a set of dice on a blue background.

The final aircraft is assigned to 5BG during January 1945. "Maiden Montana" and the state outline are on the left side of the nose. The blue shield with red stripe is on the tail surface.



**"Maiden Montana"**  
**B-24L-10-CO 44-41549, 13<sup>th</sup> AF, 5<sup>th</sup> BG, 23<sup>th</sup> BS**

Highly recommended

**Floyd S. Werner, Jr., IPMS 26266**  
**Proud IPMS NCT member since 1989**



## Upcoming Contests



**September 13, 2014**

### SuperCon 2014

<http://www.fortworthscalemodelers.org/>

IPMS Fort Worth Scale Modelers  
Bob Duncan Community Center  
Vandergriff Park  
2800 S. Center Street  
Arlington, Texas



**September 20, 2014**

### AutumnCon 2014

Theme: "What If?"

IPMS Northshore Scale Modelers  
<http://www.northshoremodelers.com/>

American Legion Hall, Post 16  
2031 Ronald Reagan Hwy.  
Covington, Louisiana



**September 27, 2014**

### 14<sup>th</sup> Annual Spoo-Doo Model Show

IPMS Central Arkansas Scale Modelers  
Statehouse Convention Center – Caraway Rooms  
101 E Markham Street  
Little Rock, Arkansas 72201



**October 4, 2014**

### ASMS Capital Classic

IPMS Austin Scale Modeler Society  
<http://www.austinsms.org>  
Norris Conference Centers  
2325 West Anderson Lane  
Austin, Texas



**October 11, 2014**

### ConAir 2014 Annual IPMS Model Contest & Expo

IPMS Air Capital Modelers  
<http://www.aircapitalipms.org/>

Midway Baptist Church  
5135 S. Broadway.  
Wichita, Kansas 67210



**November 1, 2014**

### GatorCon 2014

Theme : Fifty Shades of Gray

IPMS Acadiana Plastic Modelers  
<http://www.cajunarmor.com/IPMS-Acadiana.html>

Lafayette Event Center  
607 Johnston Street  
Lafayette, Louisiana 70503

## Upcoming Contests



**November 9, 2014**

**Veteran's Day Bassett Mall Model Display**  
IPMS El Paso <http://www.ipmselpaso.us/>  
Bassett Place Mall  
6101 Gateway West, Suite M-36  
El Paso, Texas 79925



**January 24, 2015**

**Calmex 29**  
IPMS SWAMP  
<http://ipmsswamp.com/>  
Managan Center  
1000 McKinley St.  
West Lake, Louisiana



**February 21, 2015**

**Model Fiesta 34**  
**Theme: "Critters"**  
<http://www.alamosquadron.com>  
IPMS Alamo Squadron  
San Antonio Event Center  
8111 Meadow Leaf Drive  
San Antonio, Texas 78227



**March 14, 2015**

**MCMA 2015 Showdown 25<sup>th</sup> Annual**  
<http://www.themcma.net/>  
IPMS Metroplex Car Modelers Association  
Dr. Pepper Star Center  
12700 North Stemmons Freeway  
Farmers Branch, Texas



**March 12-14, 2015**

**2013=5 Lone Star Figure Show**  
[www.lonestarfigureshow.com](http://www.lonestarfigureshow.com)  
Lone Star Military Miniature Society  
DFW Marriott South  
4151 Centreport Blvd.  
Fort Worth, Texas 76155

**March 14, 2015**

**RiverCon IV**  
IPMS Red River Modelers  
[www.ipmsredrivermodelers.org](http://www.ipmsredrivermodelers.org)  
Clarion Hotel Shreveport  
1419 East 70<sup>th</sup> Street  
Shreveport, Louisiana

**March 28, 2015**

**Great South TigerFest XXI**  
IPMS New Orleans Flying Tigers Scale Model Builders  
St. Jerome K.C. Hall  
3310 Florida Ave  
Kenner, Louisiana



**April 25, 2015**

**Model Mania 2014**  
IPMS Houston  
Theme: Technicolor  
<http://www.ipms-houston.org/>  
Stafford Center  
10505 Cash Road, Stafford, Texas



**May, 2015**

**ScaleFest 2015**  
IPMS North Central Texas  
<http://ipmsnct.net/>  
Grapevine Convention Center  
1209 South Main Street, Grapevine, Texas 76051



## Local Events of Interest



**September 4, 2014 (Thursday)**

**Lone Star Aero Club**

[www.lonestaraeroclub.org](http://www.lonestaraeroclub.org)

Col. Richard Gruenhagen: P-51 pilot and author  
DFW Airport at Hyw 360 & FAA Road  
American Airlines C.R. Smith Museum  
Fort Worth, Texas 76155



*Jimmy Leeward's Galloping Ghost*



**September 6-7, 2014**

**Red Bull Air Race**

[http://www.redbullairrace.com/en\\_US](http://www.redbullairrace.com/en_US)

Texas Motor Speedway  
3545 Lone Star Circle  
Fort Worth, Texas 76177



**September 7, 2014 (Sunday)**

IPMS MCMA

<http://www.themcma.net/>

Monthly Meeting

Irving Garden & Arts Heritage Park  
Irving, Texas 75060



**September 9, 2014 (Tuesday)**

EAA Chapter 34 Meeting

<http://www.eaa34.org>

TBD

UTA Campus Room 100, Nedderman Hall  
416 Yates Street,  
Arlington, Texas

## Local Events of Interest



**September 10, 2014 (Wednesday)**

**Marauder Men of the Metroplex**

<http://webspaces.webring.com/people/oj/jobiz/>

Business Meeting

Spring Creek Barbecue

3608 South Cooper Street,

Arlington, Texas 76015



**FORT WORTH, TEXAS**



**September 13, 2014 (Saturday)**

**OBA / FACM / VMAP**

2<sup>nd</sup> Saturday Work-Party 9:00 am to 2:00 pm

<http://www.b-36peacemakermuseum.org/>

<http://www.ov-10bronco.net>

<http://www.facmuseum.org>

3300 Ross Avenue

Meacham Airport

Fort Worth, Texas



**Scale Modelers**

**September 15, 2014 [Monday]**

**IPMS Fort Worth Scale Modelers**

<http://www.fortworthscalemodelers.org/>

No Meeting – See you at SuperCon!

Baptist Church of Benbrook

1015 McKinley Street

Benbrook, TX 76126



**September 16, 2014 (Tuesday)**

**B-36 Peacemaker Museum**

<http://www.b-36peacemakermuseum.org/>

Bill Morris: One Hundred Year Anniversary of WWI,

Training of Pilots and Support Personnel in Fort Worth, TX

UNT Health Science Center Room 124, West Building

1000 Montgomery Street

Fort Worth, Texas





## Local Events of Interest



September 27, 2014 (Saturday)

Tyler Historic Aviation Memorial Museum

<http://www.tylerhamm.org>

TBD

Tyler Pounds Airport, 2198 Dixie Drive

Tyler, Texas 75704



September 27 - 28, 2014

Fall Fly Days and Car Show

A Gathering of P-40s (5 tp 7) in honor of the last official reunion of the AVG Flying Tigers

Cavanaugh Flight Museum

<http://www.cavanaughflightmuseum.com>

4572 Claire Chennault

Addison, TX 75001



September 27, 2014

Smithsonian Magazine Day Live! – Free Admission!

WWII Vintage Aircraft

Annual Aviation Swap Meet

Author's Row!

Frontiers of Flight Museum

<http://www.flightmuseum.com/>

6911 Lemmon Avenue

Dallas, TX 75209

October 3-5, 2014

CAF World War II Air Expo

[www.AirPowerExpo.org](http://www.AirPowerExpo.org)

Dallas Executive Airport

5303 Challenger Drive

Dallas, Texas 75232



October 4, 2014

24<sup>th</sup> Annual Bid Band Hanger Dance

[www.VintageFlyingMuseum.org](http://www.VintageFlyingMuseum.org)

Vintage Flying Museum

Meacham Field

505 NW 35<sup>th</sup> Street, Fort Worth, Texas 76106



Scale Modelers

October 20, 2014 [Monday]

IPMS Fort Worth Scale Modelers

<http://www.fortworthscalemodelers.org/>

Semi-Annual Kit Auction

Baptist Church of Benbrook

1015 McKinley Street, Benbrook, TX 76126



October 25 & 26, 2014

Fort Worth Alliance Airshow

<http://www.allianceairshow.com/>

Fort Worth Alliance Airport

2221 Alliance Boulevard, Fort Worth, Texas 76177

---

# AutumnCON 2014

September 20th @ The American Legion Hall, Post 16  
2031 Ronald Regan Hwy, Covington LA.



## New Venue!

\*6000 sq ft of contest and vendor space

\*On-site food and concessions

\*Great parking

## Schedule of Events:

Vendor set-up	6 - 8am
Registration	8 - 12pm
Lunch Service	11 - 3pm
Judging / Raffle	1 - 3:30pm
Make N Take	11 - 3:30pm
Awards Ceremony	3:30 - 5pm

## Fees:

Adults	\$10 first model, \$1 each additional
Juniors	\$5 unlimited entries
Gen. Adm.	\$3

*This years theme is...*

**"PLASTIC SURGERY"**



Any subject kit that is modified/converted or any scratchbuilt subject.  
Theme model kits will be judged on the amount and execution of  
modifications or conversions.

[Contest Categories](#)

[Contest Rules](#)

[Registration Form](#)

[Model Entry Form](#)

## Vendor Info:

\$25 for 1st table, \$10 each additional

Electric available

Easy access and parking

Contact Andy @ [auseman68@gmail.com](mailto:auseman68@gmail.com)  
for table reservations





Central Arkansas Scale Modelers  
14th Annual!

# Sproo-Doo Model Show

Saturday Sept 27th

Show Theme

## D-Day

# casmodels.org

Show Coordinator, Brianna Childres  
[casmodelers@gmail.com](mailto:casmodelers@gmail.com)



Statehouse Convention Center  
- Caraway Rooms -  
101 E Markham St. Little Rock, AR 72201





Presented and Hosted by:



Dallas Area PONTIAC Association



**New for 2014!**

All Pontiac Show on Saturday

All American Makes Show on Sunday

Race on Sunday

Building on a 20 year tradition of success, this year's *Pontiac Southern Nationals* promises to be the best ever. Held on the grounds of the Cavanaugh Flight Museum in Addison in conjunction with their *Fall Fly Days*, there will be two full days of opportunity to show your car and have it *independently judged*. On Saturday bring out your Pontiac to be seen and appreciated. If racing is your 'thing', on Sunday we'll also be offering the opportunity to participate in the Texas Muscle Car Club Challenge race at North Star Dragway in Denton. (Race registration is separate and must be paid at the track). Also on Sunday we're inviting all American makes of cars, trucks, and bikes to "show your stuff" at the *American Pride Car Show*. Your daily show registration includes access for yourself and all passengers in your show vehicle to the museum exhibits and other special events we have planned for that day. After all, 2014 marks the *50<sup>th</sup> Anniversary* of the car that started it all, the mighty *Pontiac GTO*.

**Fifty Years of The GREAT ONE 1964-2014**

PSN : Sponsors



**PSN: Saturday, September 27, 2014**  
Cavanaugh Flight Museum  
4572 Claire Chennault, Addison TX 75001  
8:30am – 11:00am = Registration  
11:00am – 3:00pm = Show  
3:15pm = Awards

Mail Entry Form and Fee to: Pontiac Southern Nationals  
P.O. Box 831605  
Richardson, TX 75083

Name \_\_\_\_\_  
Address \_\_\_\_\_  
City \_\_\_\_\_ State \_\_\_\_\_ Zip \_\_\_\_\_  
Phone \_\_\_\_\_  
E-Mail \_\_\_\_\_  
Car Year \_\_\_\_\_ Make \_\_\_\_\_ Model \_\_\_\_\_  
Circle: (PSN Saturday \$25 Pontiacs Only) (APCS Sunday \$25)  
(Both Days \$40 Pontiacs Only) Amount Included: \_\_\_\_\_  
Primary Club Affiliation \_\_\_\_\_

Entry Confirmation will be advised by Email if received before Aug 24<sup>th</sup> 2014. All other materials will only be issued at the event during Registration.

**Entry Fees:**  
PSN/APCS Show: \*\$25 one day / \$40 both days  
\* Show Fee includes entry to Flight Museum

**Car Show Registration:**  
•Register on Line at [www.dapa.org](http://www.dapa.org) (PayPal)   
•Mail Entry Form and Check to address on form  
•Register on site at the Car Show

**Sun. TMCCC Race - Pay at the Track - ONLY**  
Race Participants: \$30.00  
Race Spectators: \$12.00

Benefiting:



TMCCC Race Info:  
[www.tmccc.org](http://www.tmccc.org)

Contact: <http://www.dapa.org>  
Email: [psn@dapa.org](mailto:psn@dapa.org)  
Phone: (972) 428 8571

**Note: Pre-Registration assures Express Check-In at the on-site PSN Registration Desk**





# WORLD WAR II AIR EXPO

A GATHERING  
OF WWII AIRCRAFT

Featuring "FAI"

The World's Only Flying  
B-29 Superfortress



**OCT. 3-5**  
9 A.M. - 5 P.M. DAILY



**DALLAS EXECUTIVE AIRPORT**

### FEATURING:

B-29 Superfortress  
B-24 Liberator  
P-51 Mustang  
SB2C Helldiver  
C-45 Expeditor  
Military Vehicles  
Vintage Cars  
Aircraft Rides  
Food, Drinks and More...

### SPECIAL GUEST:



See the Red Tail RISE ABOVE  
Exhibit and P-51C Mustang.  
Watch the *Rise Above* movie  
featuring Tuskegee Airmen of WWII  
**FREE** with paid admission.

### INFORMATION:

General Admission At Gate  
Adults (Ages 18 and up): \$15  
Youth (Ages 6 - 17): \$5  
Kids (5 and under): FREE

Dallas Executive Airport  
5303 Challenger Dr.  
Dallas, Texas 75232



[www.AirPowerExpo.org](http://www.AirPowerExpo.org)



# Austin Scale Modeler's Society

*presents*



**Saturday October 4<sup>th</sup>, 2014**

**Norris Conference Centers**  
2525 West Anderson Lane, Austin, TX

**Show Theme:**



Any model of a prototype, one of a kind, first place finish,  
record breaker, or any other kind of "first"

For latest info, please visit **[www.austinsms.org](http://www.austinsms.org)**



# Build for Victory!

**HISTORY  
THROUGH  
MODELING**

*International Plastic  
Modelers Society*



**JULY 22-25, 2015**

Hosted by IPMS Eddie Rickenbacker • [www.ipmsusa2015.com](http://www.ipmsusa2015.com)

# HAMS

Contact Rob at [robert.mcquown@sbcglobal.net](mailto:robert.mcquown@sbcglobal.net) with any questions and for vendor tables. See the club webpage for updates and map of show location:

[www.ipms-hams.org](http://www.ipms-hams.org)

## Eight Annual Model Car Show and Contest

Supported by Cypress Creek Christian Community Center

# Remembering Orphaned Marques

### Schedule

8:00 AM to 9:30AM Vendor set up only  
9:30 AM to 5:00PM Show open to public  
9:30AM to 1:30PM Contest area open  
1:30PM to 3:00PM Contest area closed for Judging  
3:30PM to 4:00PM Awards Ceremony  
4:00PM to 5:00PM Display and vendor break down

**Admission:** \$1 donation includes first door prize ticket

### Contest entry fees:

Adults (18+) \$10 for first 2 entries, \$2 dollars each per additional entry.  
Teens (13-17) \$5 for first 2 entries, \$1 each per additional entries.  
Junior (under 12) \$1 for all you may enter.

**Make N Take for the kids starting at 12 noon**

*Any car no longer in production such as AMC, Nash, Packard, Hudson, Stanley, and many others that have become obscure in today's world. All out of production American and foreign manufacturers are eligible.*



**Vendor tables will be available on first reserved basis at \$20 per table space. Last day to reserve is July 25, 2014.**

**Categories:** Include; Box Stock, Street Rod, Street Machine, Factory Stock, Competition open-wheeled, and closed-wheeled, Foreign, Large and small commercial vehicles, large and small scale, Curbside, Miscellaneous, Custom, Diorama, Slammers, Motorcycles, Low riders. See club web site for details.

**Awards:** 1st, 2nd, 3rd will be presented in 21 categories. There also will be special awards for Best Paint, Engine, Interior, '32 Ford, Short track car and the Contest Theme.

**Food and drink will be available at a nominal cost.**

**Saturday August 02, 2014 9:30AM to 5:00PM**

**Cypress Creek Christian Community Center  
Annex Building Gym  
6823 Cypresswood Drive  
Spring, Texas 77379**





<http://www.ipmsusa.org/>

## Membership

**IPMS/USA** is an organization dedicated to the fun of Scale Modeling. It was started by Jim Sage, of Dallas, Texas, in 1963. There are now branches of IPMS all over the world. Many of our Local Chapters and Regions sponsor Model shows and contests every year. Of course, you needn't be a member to just visit the shows, or attend the clubs.

As part of your IPMS/USA Membership, you will receive **The Modeler's Journal** six times a year. In it you will find stories of interest on subjects such as aircraft, armor, automotive, ships, figures, you name it. You will also find listings of IPMS contests and swap meets, hints and tips, and reviews.

Membership also qualifies you to participate in IPMS/USA sanctioned **Regional Contests**, as well as our World-famous **National Convention**, held each summer. As a member, you'll also be able to access our online Member's Forum where a wide variety of Society and Modeling topics are discussed, and enjoy real-time access to other Modelers for help with questions about Modeling or the Society in general.

In addition, many Hobby Shops around the county offer discounts to IPMS/USA Members. Memberships are available in several packages:

**Junior** 17 years old or Younger, \$12.00 per year

**Adult** 1 Year, \$25.00    2 Years \$49.00    3 Years \$73.00

**Family** Adult Membership plus \$5.00 (Additional Membership cards as requested)

**Canada or Mexico** \$30.00 per Year

**Foreign** \$32.00 per Year (Journal via Regular Mail) or \$55.00 per year (Journal via Air Mail)

Payment Information: Payment may be made via Personal Check, Money Order, or Credit Card. Applications using payment via Check or Money Order should be printed upon completion of the registration process, and mailed to:

**IPMS/USA  
Dept. H  
PO Box 2475  
N. Canton, OH 44720-0475**

For any questions or problems with your membership application/renewal, please contact the IPMS/USA Officer Manager, Ms. M.J. Kinney, at [manager@ipmsusa.org](mailto:manager@ipmsusa.org)

## Babe Of The Month Sienna Tiggy Guillory



Sienna Tiggy Guillory (born 16 March 1975) is an English actress, and former model. She is known for playing the title role in the TV miniseries, *Helen of Troy*, her portrayal of Jill Valentine in the science fiction action horror film *Resident Evil: Apocalypse*, and as elf princess Arya Dröttningu in fantasy-adventure film, *Eragon*.





She resumed her role as Jill Valentine for a cameo appearance in the 2010 action-horror film *Resident Evil: Afterlife*, and in *Resident Evil: Retribution*, released on 14 September 2012.

Born in Kettering, Northamptonshire, England, Guillory is the daughter of the American folk guitarist Isaac Guillory and his first wife, English model Tina Thompson, whom he married in 1973. Isaac Guillory was of Jewish heritage and born at the Guantanamo naval base in Cuba, the son of an American sailor and his Turkish wife.



Her parents moved to Fulham, London when Guillory was two, then later to Norfolk when she was 11. At the age of ten, she went to stay with cousins in Mexico to learn Spanish.

She has a half-brother named Jace, whom her father had adopted and with whom she shares the same mother. Her parents divorced in 1990 when she was 14, and in 1993, her father married Vickie McMillan, which resulted in a much younger half-sister and half-brother, Ellie and Jacob.

Guillory attended Gresham's School in Holt, Norfolk, where she took part in numerous school productions. Guillory has been an equestrian since the age of two.







At 14, she was given a horse, which she named The Night Porter, or "Porty", after the film *The Night Porter*; Guillory was a fan of its leading actress Charlotte Rampling. In December 2000, Guillory's father died of cancer at the age of 53.

In 1997, Guillory accompanied a ballerina friend to the London modelling agency Select and was soon signed. She modelled solely to support her acting career. As a model, she worked in campaigns for Armani, Dolce & Gabbana, Burberry, and Paul Smith and appeared on the covers of several fashion magazines.



and appeared on the covers of several fashion magazines. In 1999, she became the face of the Hugo Boss fragrance campaign, succeeding model Karen Ferrari and continuing the campaign for three years. After modelling for a few years, Guillory returned her focus to acting in 2000. She is signed to Independent Models in London.

Guillory explained that she "became an actor because I wanted to know what it was like to be other people. Because possibly I don't like myself", and later said "I hate acting, really hate it. I kind of fell into it sideways ... I started acting because I got offered a job when I





was 16, and they wanted to pay me £8,000, and we'd always lived on Family Support..." She went on to say that her frustration with later film roles left her bitter, but after seeing Helen Mirren onstage she was inspired again.

In 1993, Guillory made her screen debut in a TV adaptation of Jilly Cooper's novel, *Riders*, for which the casting directors needed a young actress who was able to ride a horse. Her performance landed her in another small role in the miniseries *The Buccaneers*, opposite Mira Sorvino.

Before becoming a model to support her acting career, Guillory waited tables at a club. In an interview in 2000, she said about the experience "Supporting my



acting habit with waitressing was probably the most useful thing I've done."

During her time as a model, she studied acting at the New World School of the Arts and the Paris Conservatoire, also taking small television and film roles in *The Future Lasts a Long Time* (1996), *The Rules of Engagement* (1999), *Star! Star!* (1999), *Kiss Kiss (Bang Bang)* (2000), *The 3 Kings* (2000), and *Two Days, Nine Lives* (2000).

During this time, Guillory decided to go on with her acting career because "I was so scared of going to university and being with people my own age again, having been with that tiny little sect of girls in Norfolk whose daddies were farmers and politicians, who didn't trust me and didn't know where I was coming from".

She returned to film with a more substantial role in the thriller *Sorted* (2000). Guillory went on to appear in the BBC production *Take a Girl Like You*, a television adaptation of Kingsley Amis's novel of the same name. She portrayed Jenny Bunn, the story's virginal heroine, and gained critical attention for her part in the period piece.







Guillory was pleased to have played a more innocent character, saying "I've played floozies, psychopaths, assassins, crackheads... It's nice to do something with a lighter touch." The production did not fare well in the ratings.

In 2001, Guillory continued with other roles in predominantly British films, including *Oblivious*, *Late Night Shopping* (with husband Enzo Cilenti), *The Last Minute*, and *Superstition*. 2002 saw Guillory appear in *The Time Machine*, alongside Guy Pearce and Jeremy Irons.

She was pleased to take on a larger scale film, after having worked on low-budget independent films, and compared the experience with "finding an unicorn in your sock drawer". She played Emma, the fiancée of Pearce's character, who was killed early in the film and whose death set off its main events.

In 2003, after a friend had received a script for *The Principles of Lust*, Guillory claims she "read it and couldn't put it down, and begged to read for the part". She was impressed by director Penny Woolcock's unconventional style of shooting, without rehearsing the actors, using raw takes and improvisational performances.

For the role of Juliette, Guillory performed nude in the film's sex scenes which were filmed during the first week of filming, making her somewhat nervous. She later went on to say that it was one of her favorite acting experiences.



Afterwards, Guillory had a small role in the romantic comedy *Love, Actually* before taking the starring role in the television miniseries *Helen of Troy*. The series was mostly based on Homer's epic poem *Iliad* and focuses on the mythological life of Helen. *Helen of Troy* was nominated for best miniseries at the Satellite Awards.

In May 2004, Guillory starred in a new stage production of *The Shape of Things* at the New Ambassadors Theatre in London, with husband Cilenti. 2004 also saw Guillory in her first big Hollywood role. She was cast as Jill Valentine, one of the lead characters in the video game adaptation sequel *Resident Evil: Apocalypse*.

The film makers had searched widely for an actress to portray the video game character and found her in Guillory, who had to "please not only the movie-going audience but also the gamers". She was, however, "a dead ringer for Jill Valentine".

Guillory was reported to have studied the original character's movements by watching playthroughs of the video game *Resident Evil 3: Nemesis*. Before getting the script for the film, she had not been familiar with the video games or seen *Resident Evil*. She said about her role:





“ You always want to play someone you’re going to have fun with, someone you want to be. Jill’s got everything a girl wants to be – she dresses to kill, says whatever she wants and can shoot anyone between the eyes in a 50-yard radius. She’s hard as nails and she’s great fun. And not at all afraid of being quite the sexy minx. ”

*Resident Evil: Apocalypse*, although it was not well received by critics, grossed \$23,036,273 on its opening weekend (10–12 September 2004) and took a total of \$51,201,453 in the United States and \$129,394,835 worldwide.

After the success of *Resident Evil: Apocalypse*, Guillory went on to appear in other film and television roles, including *Beauty* (2004), *Marple: A Murder Is Announced* (2005), *In the Bathroom* (2005), *The Virgin Queen* (2005), *Silence Becomes You* (2005), and *Rabbit Fever* (2006).

In 2006, Guillory was a lead in the ensemble cast of the fantasy *Eragon*, the film adaptation of the novel by Christopher Paolini; the role had reunited her with *The Time Machine* co-star Jeremy Irons. She portrayed Arya Dröttningu, an elf princess. She had not read the novels before filming, but after accepting the role she soon became a fan of Paolini’s work.

Although Arya is a key character in the film, Guillory had little screen time and went on to say jokingly:



"I've been trying to explain to friends who've seen the trailer [...] I'm like, "[...] but that's my whole part!""  
*Eragon* was not well received by the critics, but was nominated as Best Fantasy Film at the 2006 Saturn Awards. The film went on to gross approximately \$75 million in the US and \$173.9 million elsewhere, totalling \$249 million worldwide. Guillory was also invited to reprise her role as Jill Valentine in *Resident Evil: Extinction*, the sequel to *Resident Evil: Apocalypse*, but could not accept due to scheduling conflicts with *Eragon*.

In 2007, she starred in the Spanish production *El Corazón de la tierra*, or *The Heart of the Earth*, and later in the year finished filming the horror/thriller *Victims* and the fantasy novel adaptation *Inkheart*. In *Inkheart*, she plays Resa, the wife of Brendan Fraser's character and the mother of Eliza Bennett's. *Inkheart* sees Guillory acting alongside Helen Mirren, a friend of the Guillory family who was a role model when she first had aspirations towards acting.

Guillory will be a lead in the forthcoming television series *The Oaks*, expected to begin airing in 2008. She joins Bahar Soomekh, Matt Lanter, Romy Rosemont, Jeremy Renner, Michael Rispoli and Shannon Lucio in the series which follows the intertwining stories of three







In 2001, readers of *Esquire* UK voted Guillory "Britain's Most Eligible Woman" and featured her in a pictorial in the magazine. Guillory was photographed for the cover and shoot by photographer Jonathan Glynn Smith. In 2002, she was number 89 on *Maxim's* list of "The 100 Sexiest Women", and in 2007 Guillory was voted number 54 at Askmen.com's Top 99 Countdown.

Guillory has also been quoted as disliking the Hollywood culture, saying she does not wish to be part of it:

“ I went out the other night for the first time in ages, just because I'd been so busy. As I came out of the cinema, I ran down the street to get cigarettes, and 30 guys followed me with cameras and shouted at me. It's all so strange. It's not a life I really live or understand.

In 2000, Guillory began dating Enzo Cilenti, and the couple married in 2002. In February 2011, Guillory gave birth to twin daughters, Valentina and Lucia Cilenti, named after her grandmother and great aunt who were also twin sisters.

In August 2004, Guillory and Cilenti cycled five stages of the Tour de France to raise money for charity.

families—a young couple in 1968 that have lost a child, a family of four in 1998, and a pregnant couple in 2008—who are haunted by the same spirit in their house. The television series began filming on 5 November 2007 on location in Pasadena, California. Guillory will play Jessica, the 2008 couple's neighbour, a woman who has Asperger syndrome who went to school with the husband (and father-to-be) and shares a secret with him.

In May 2010, *Shock Till You Drop.com* confirmed the return of Jill Valentine in the *Resident Evil* film franchise's fourth instalment, *Resident Evil: Afterlife*. with Guillory reprising the role. On 31 May, Jovovich also confirmed that Guillory would return as Jill. Guillory reappears in the film in a mid-end credit scene. She returned to a starring role in the following film, *Resident Evil: Retribution* as the main antagonist.







## Museums

### American Airlines C. R. Smith Museum

<http://www.crsmithmuseum.org>

Fort Worth, Texas 76155



### Cavanaugh Flight Museum

<http://www.cavanaughflightmuseum.com>

4572 Claire Chennault  
Addison, TX 75001



### Cold War Air Museum

<http://www.coldwarairmuseum.com/>

Lancaster, Texas 76106



### Corsair (Goodyear FG-1D), Commemorative Air Force

[www.caf-corsair.com](http://www.caf-corsair.com)

Lancaster Municipal Airport  
630 Ferris Road, Lancaster, Texas 75115



### Dallas-Fort Worth Wing, Commemorative Air Force

<http://www.dfwwing.com/>

Lancaster Municipal Airport  
630 Ferris Road, Lancaster, Texas 75115



### Flight of the Phoenix Air Museum

[www.flightofthephoenix.org](http://www.flightofthephoenix.org)

Hanger One, Gilmer Texas 75644



### Frontiers of Flight Museum

<http://www.flightmuseum.com/>

6911 Lemmon Avenue Dallas, Texas

## Hangar 10 Flying Museum

### Hangar 10 Flying Museum

<http://www.hangar10.org/Site/Home.html>

1945 Matt Wright Lane  
Denton Municipal Airport  
Denton, Texas 76207



### National WASP WWII Museum

<http://www.waspmuseum.org>

Sweetwater, Texas



### OV-10 Bronco Museum

<http://www.ov-10bronco.net>

3300 Ross Avenue, Meacham Airport, Fort Worth, Texas



### Ranger Wing, Commemorative Air Force

[www.rangerwingcaf.com](http://www.rangerwingcaf.com)

Blackland Aircraft Corp. Hanger  
Airport Blvd., Waco, Texas



### Silent Wings Museum

[www.silentwingsmuseum.com](http://www.silentwingsmuseum.com)

6202 North I-27 Lubbock, Texas 79403

BG John C. E. Scribner



### Texas Military Forces Museum

Camp Mabry Austin Texas

### Texas Military Forces Museum

<http://www.texasmilitaryforcesmuseum.org>

Camp Mabry, Austin, Texas



### Tyler Historic Aviation Memorial Museum

<http://www.tylerhamm.org>

Jake Smith Exhibit Hall Tyler, Texas

## Vintage Flying Museum

Featuring "Chuckle" one of the few remaining flying B-17's in the world

### Vintage Flying Museum

<http://www.vintageflyingmuseum.org>

505 NW 38TH ST. Hangar 33 South, Fort Worth, Texas

## Local Plastic Emporiums



### M-A-L Hobbies

<http://www.malhobby.com>  
108 S. Lee St., Irving, TX 75060  
(972) 438.9233

### HobbyTown USA Fort Worth



[http://www.hobbytown.com/Fort\\_Worth-TX/](http://www.hobbytown.com/Fort_Worth-TX/)  
677 Sherry Lane  
Fort Worth, TX 76116  
(817) 735-0021

### HobbyTown USA Dallas



The Corner Shopping Center  
<http://hobbytown.com/TXDAL/>  
8041 Walnut Hill, Suite 870  
Dallas, TX 75231  
(214) 987-4744

### HobbyTown USA Arlington



<http://hobbytown.com/TXARL/>  
4634 South Cooper St  
Arlington, TX 76017  
(817) 557-2225

### HobbyTown USA Plano



<http://hobbytown.com/TXPLA/>  
3303 N. Central Expressway  
Plano, TX 75023  
(972) 424-8493

### HobbyTown USA Hurst



746 Grapevine Highway  
Hurst, TX, 76054  
(817) 581-1027

### HobbyTown USA Tyler



French Quarter Shopping Center  
<http://hobbytown.com/TXTYL/>  
4566 S. Broadway  
Tyler, TX 75703  
(903) 509-3000

### Mason's Hobby Lobby



6905 Grapevine Hwy.  
Fort Worth, Texas 76180  
(817) 284-0264

### Roy's Hobby Shop



1309 Norwood DR.  
Hurst, TX 76053  
<http://www.royshobby.com/>  
(817) 268-0210

### Wild Bill's Hobby Shop



535 East Shady Grove Rd.  
Irving, Texas 75060  
(972) 438-9224



# New Ware 1/144 Mercury Redstone 4 - Liberty Bell 7 LV

By Sven Knudson, IPMS 32490

[www.ninfinger.org](http://www.ninfinger.org)



*The kit box has a drawing of the launch vehicle and spacecraft.*



*Astronaut Gus Grissom climbs into his 'Liberty Bell 7' spacecraft, 07/21/61.*

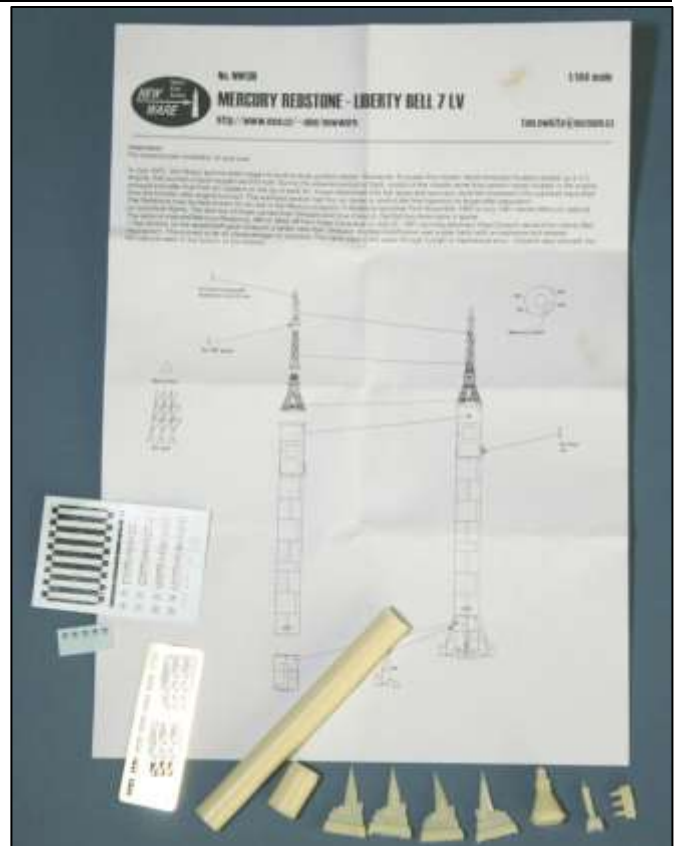

*Here's what you get in the kit.*

## Background

Mercury spacecraft #11 was designated to fly the second manned suborbital flight in October, 1960. It came off McDonnell's St. Louis production line in May 1960. Spacecraft #11 was the first Mercury operational spacecraft with a centerline window instead of two portholes.

It was closer to the final orbital version than was Alan Shepard's *Freedom 7*. Dubbed *Liberty Bell 7*, it featured a white, diagonal irregular paint stripe starting at the base of the capsule and extending about two-thirds toward the nose, emulating the crack in the famed Liberty Bell in Philadelphia, Pennsylvania.

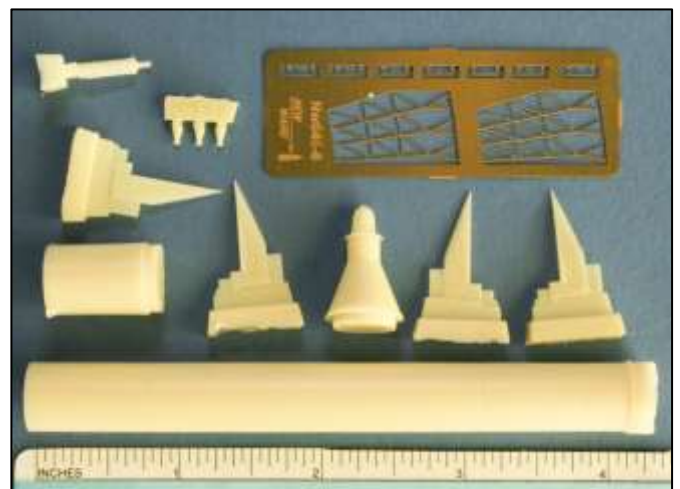

*Here's a closer look at the parts.*

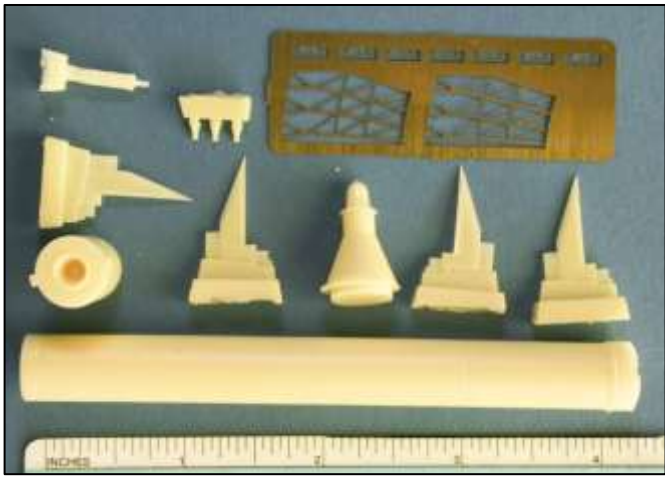

*Here's another side of the parts.*

The flight lasted 15 minutes 30 seconds, reached an altitude of more than 102.8 nautical miles (190.4 km) and traveled 262.5 nautical miles (486.2 km) downrange, landing in the Atlantic ocean.

The flight went as expected until just after splashdown, when the hatch cover, designed to release explosively in the event of an emergency, accidentally blew. Grissom was at risk of drowning but was recovered safely; the capsule sank into the Atlantic and was not recovered until 1999.

**Kit contents:** 11 resin parts  
 9 photoetched parts (includes extras)  
 decals  
 instructions

**Comments**

The resin parts are solid, with crisp details, finely engraved panel lines, a smooth surface finish and no visible airholes. All parts are still attached to their pour plugs. The Mercury capsule represents Gus Grissom's Liberty Bell 7 which represented the orbital version of the spacecraft. Extra photoetched parts of the escape tower and Redstone antennae are provided, which is always nice.

The instruction sheet includes a short program history, an exploded assembly drawing with inset details and a four-view painting and decaling guide. Alps decals are provided for the Liberty Bell 7 specific markings, including the crack.

**Price:** \$ 28.00 plus shipping

**Order from:** New Ware  
 ing. Tomas Kladiva  
 Klimkova 5  
 710 00 Slezska Ostrava  
 CZECH REPUBLIC  
 email: [tom.nwkits@seznam.cz](mailto:tom.nwkits@seznam.cz)  
 web:  
<http://www.mus.cz/~ales/newware/>

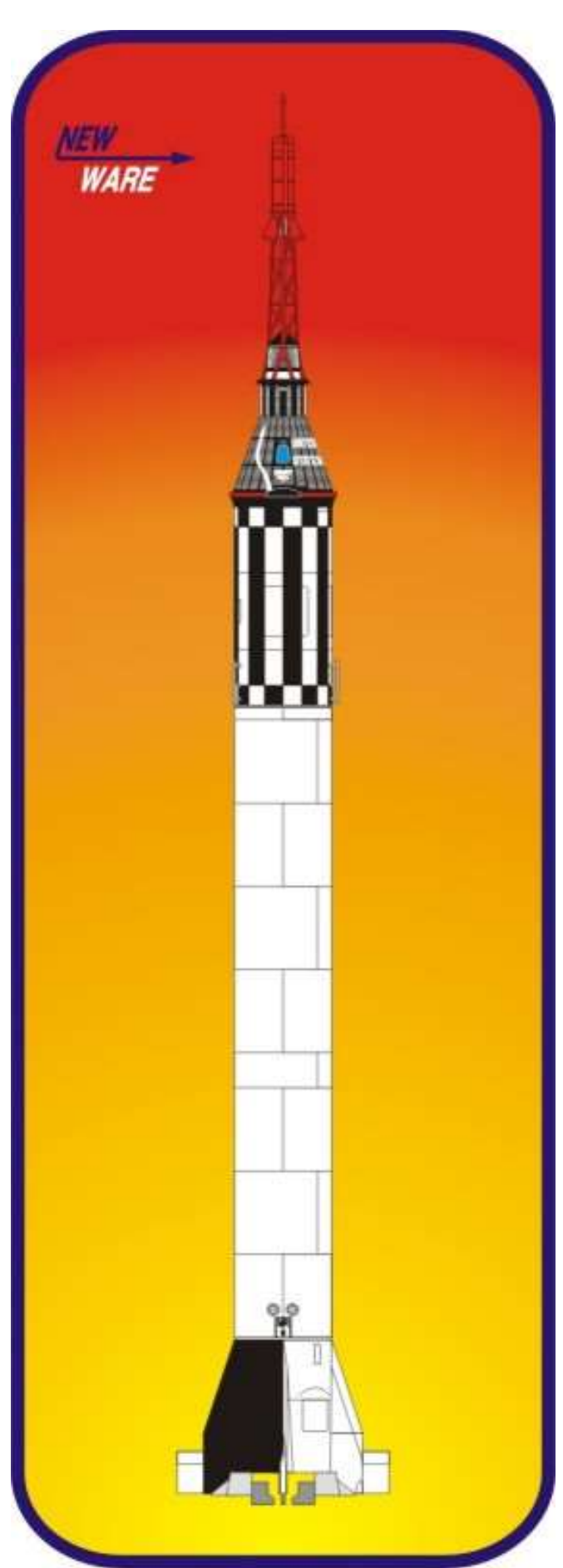



# Tamiya 1/48

## US 2 1/2 Ton 6x6

### Airfield Fuel Truck

By Cookie Sewell



- Kit Number:** 32579
- Media:** 153 parts (143 in olive drab styrene, 8 clear styrene, 1 length of vinyl tubing, 1 section coated wire)
- Pros:** Nice new kit of this popular vehicle in this scale; wide opportunities for conversions and use in multiple situations
- Recommendation:** Highly Recommended for all GMC fans as well as aircraft modelers
- Price:** US \$ 37.99

Like other manufacturers, Tamiya likes to introduce new versions using proven kit parts to expand their offerings and cover more bases. This nice little kit is based on their CCKW cargo truck kit (No. 32548) but adds or replaces 84 parts from that kit.

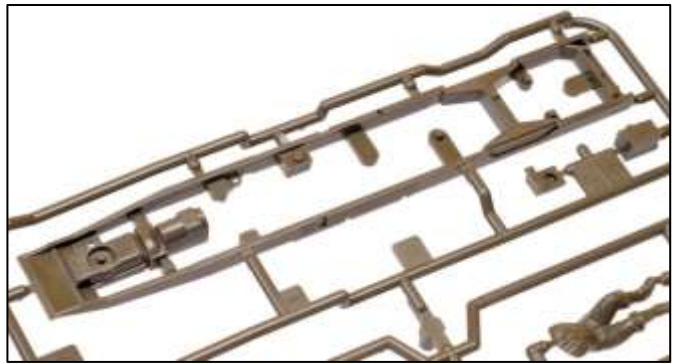
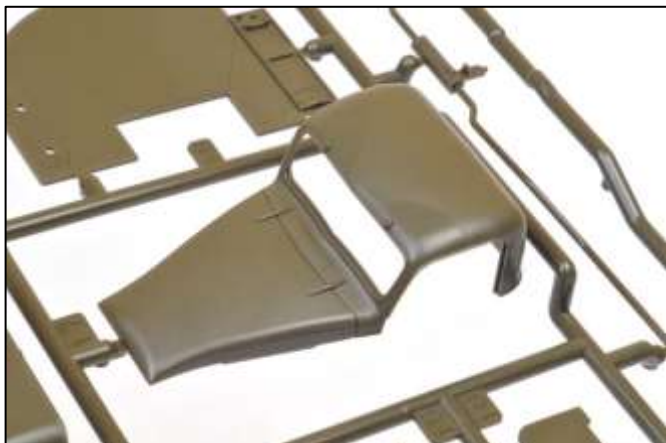

This kit is a nicer effort than the relatively stripped down CCKW kit in that it comes with all that it needs to in order to replicate its subject. The original driver figure is included and now two others are added, one man in a helmet and one in a soft cap handling the hoses.

This kit replaces one of the problems in the original kit – a diecast chassis which required screws for assembly and made building a “clean” model more difficult, as well as any conversions nearly impossible without scratchbuilding a new chassis.



The model provides the “hard” cab with optional position doors and an open section of the pumping facility on the tanker with two hose reels and two nozzles. While basic this is nicely details and includes the pressure tank and a fire extinguisher.



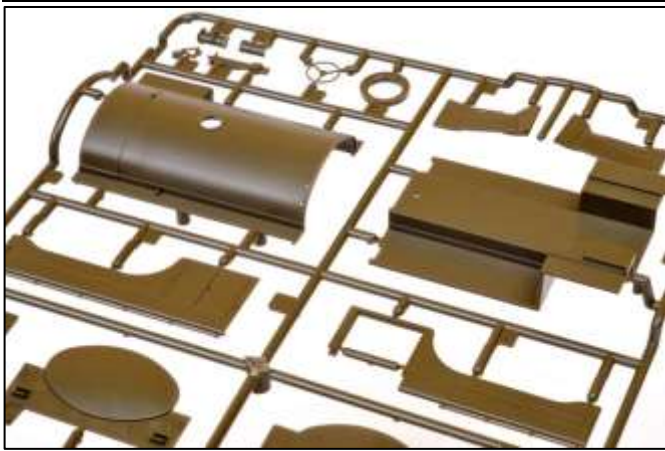

Cab detail is on a par with older 1/35 scale kits in that it has all of the lever controls and the wheel but no foot pedals (even absent from the floorboard due to an oversize mount for the steering column.) The driver and standing figure with helmet are neatly done but come with leggings, which limits them to WWII applications.



The wheels have been simplified as only the front wheels have an interior side to them, as the rear wheels are simply stuck together and the spare is likewise missing the backs side.

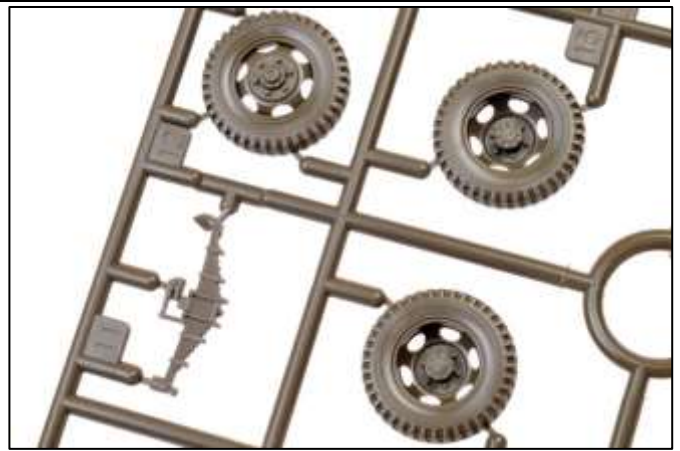

The driveline in this kit has been cleaned up for assembly via cement and glues to the chassis vice the screws of the original. The entire driveline is one piece less the springs.

The kit comes with two finishing options, both in basic olive drab. It is either USAAF in France or USAAF in France June 1944. Both trucks have white markings but no unit codes (one has an ace of spades, the other white patches with nothing else).

Overall this kit is a good one and can be used for dioramas well into the 1950s. I do wish they had offered a yellow or red scheme for it though.

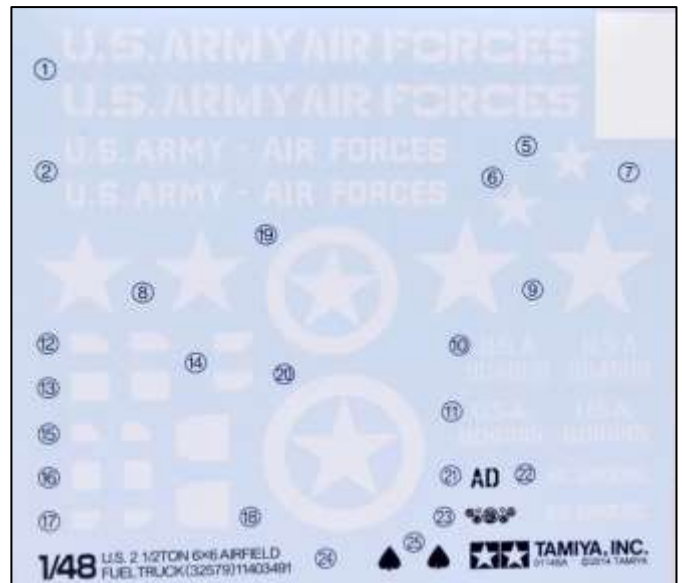

### Sprue Layout

- A 2x31 Wheels, suspension, seats, details
- B 19 Driveline, driver, front fenders
- C 22 Cab, cargo body
- E 33 Cab, tanker body, exhaust
- G 8 Clear Styrene
- H 26 Two figures, tanker parts, fuel nozzles
- – 1 Vinyl tubing
- – 1 Coated wire

*Cookie Sewell*





*Buddy  
Air  
Wolfe*





*Air Power Expo 2014 Carswell AFB*

*Photos Copyright © by Buddy Wolfe*



## Yak Image of the Month



*North Korean Yak-9P captured during Korean War*



---

# Naval Nostalgia

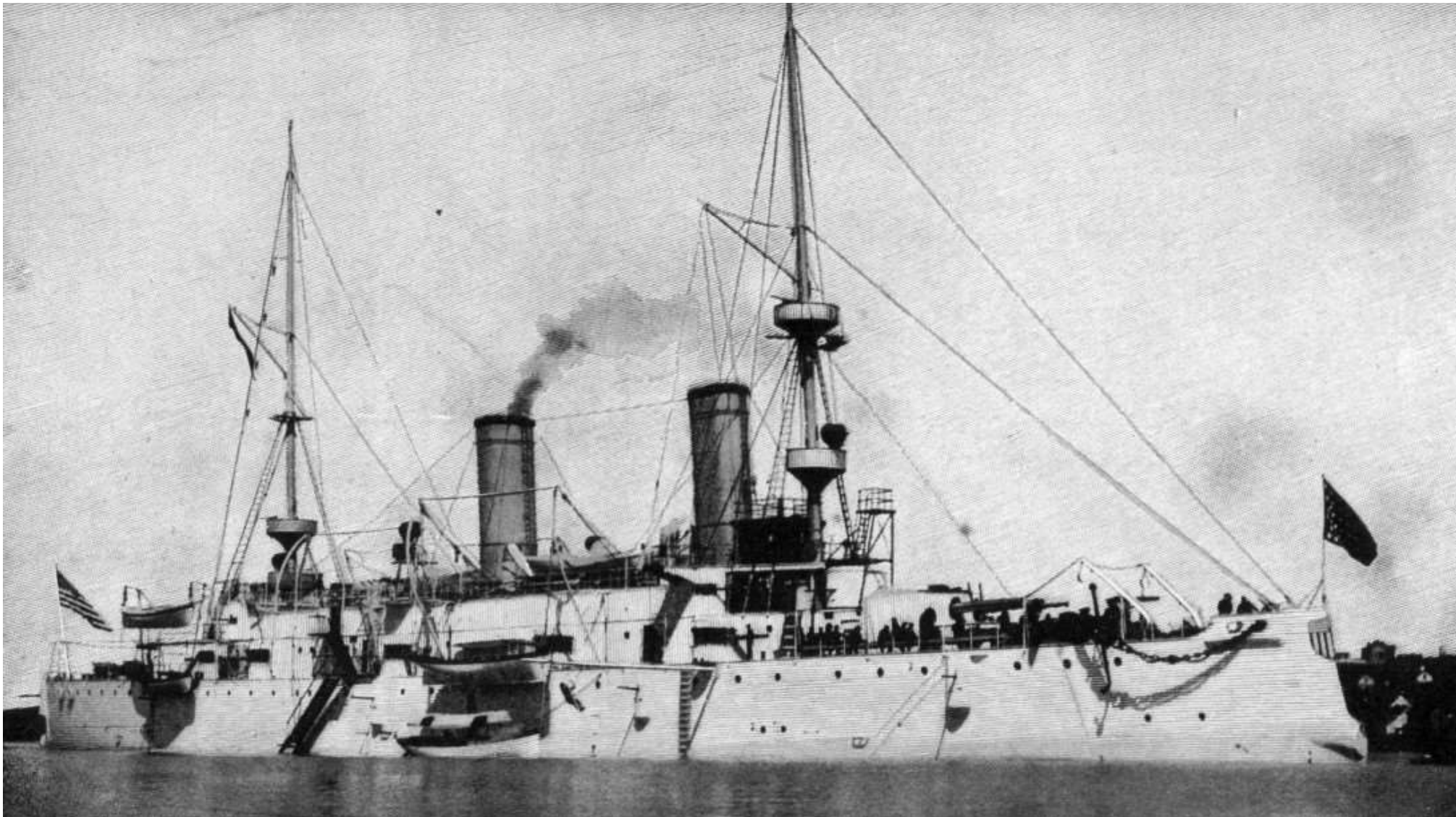

*The protected cruiser "Olympia", Admiral Dewey's flagship. (date unknown of photo published in 1899)*



# Aerial Nostalgia



*Cole Palen's F.E.8 reproduction in flight at Old Rhinebeck Aerodrome, early 1980s during one of the Aerodrome's weekend airshows.*

---

# Rat of the Month



**Ski-equipped type 5 'red 3' of 13th Avio Escadrille of the 61st Avio Brigade of the Red Banner Baltic Fleet Air Force during the Winter War.  
The plane was flown by Senior lieutenant Novikov**



# Art for Art's Sake



**“In Sunlit Silence”, T-39A Sabreliner, 1401st MAS’s Detachment A from Peterson AFB, 1976; 18” x 24” oil on canvas, 2004, © Gerald Asher**

# Tail Shot



**Clark Ho-Hauler 2 powered by a Vendenyev M14P, N397HH, Meacham Field, Fort Worth, Texas  
Photo © by Jay Miller, IPMS #45, Proud IPMS-NCT member since 1964**



## IPMS North Central Texas

President:	Michael McMurtrey	(972) 245-2545	<a href="mailto:skyking918@verizon.net">skyking918@verizon.net</a>	IPMS USA # 1746
Vice President	Randy Spurr		<a href="mailto:rls4440@yahoo.com">rls4440@yahoo.com</a>	IPMS USA #
Contest Director	Lynn Rowley		<a href="mailto:ldr.rocket@gmail.com">ldr.rocket@gmail.com</a>	IPMS USA # 31765
Treasurer:	Trevin Baker	(214) 797-9766		
Secretary	Ed Grune	(817) 473-8492	<a href="mailto:efgrune@att.net">efgrune@att.net</a>	IPMS USA#
Facebook Director	Richard Hanna		<a href="mailto:rwhanna@swbell.net">rwhanna@swbell.net</a>	
Hannibal Lecter:	James Sharp		<a href="mailto:boxstock@txrr.com">boxstock@txrr.com</a>	

IPMS North Central Texas meets on the second Sunday of every month. Door opens at 1:00 p.m.; meeting begins at 1:30 p.m. See *Coming Events* for which facility the current meeting is being held.

The FlakSheet is a monthly publication of IPMS-NCT and is used to communicate chapter news, functions, contest information, and other events or items of interest on the local, regional, and national scenes. Subscriptions are 460 Kronor annually for an electronic subscription via email.

The views and opinions expressed in this newsletter are those of the authors and should not be construed as the views or opinions of IPMS North Central Texas or IPMS/USA.

Editor: Frank Landrus ([viggenja37@sbcglobal.net](mailto:viggenja37@sbcglobal.net)) IPMS USA # 35035, IPMS-NCT Member since 1985.

**Deadline for submissions to the *FlakSheet* is the 25<sup>th</sup> of the month prior to month of issue. Please submit as a WORD or ASCII text file on compact disc at the meeting or as an attachment via email to your editor.**

